

## Important safety instructions! Please read before connection!



### **DANGER! (Electrical shock due to high voltages in the device)**

The housing must not be removed! There are **no** parts to be maintained in the device. Inside the unit there are components which are under high electrical voltage.

Before each use, check the device for damage or the absence of components, protective devices or housing parts. If this is the case, the device must not be used!

Leave maintenance and repair work to a qualified service workshop or contact your dealer. In the case of a malfunction of the device, operation must also be stopped immediately until the device has been repaired by a specialist!



### **DANGER! (Electric shock due to short circuit)**

Modifications to the power cord or plug are prohibited. If the power cord is damaged, it must be replaced immediately with an original spare part from the manufacturer. Failure to do so may result in fire or death due to electric shock!



### **DANGER! (For babies and children)**

Dispose of or store any packaging material properly! Packaging material must be kept out of the reach of babies and children due to the **risk of suffocation**.

Ensure that children never use the appliance unattended! In addition, make sure that children do not remove (small) parts from the device, as they could suffocate by swallowing parts!



### **Hint! (Fire hazard due to overheating)**

The maximum permissible ambient temperature of this device is **-5 to +45°C**.

Ensure that the unit is placed in a location with adequate ventilation, out of the reach of direct heat sources, open fire and flammable materials and liquids. A minimum distance of 1 m is required.

Do not tape or cover the ventilation slots of the unit.



### **DANGER! (Dealing with granules)**

The granulate is a dangerous combustion product that can ignite spontaneously when exposed to air or moisture and thus lead to fires and explosions. Keep it away from heat, hot surfaces, sparks, open flames and other sources of ignition. Do not smoke. Always protect from moisture. Avoid dust formation. Always wear protective clothing, gloves and goggles. Always provide adequate ventilation.

The material reaches very high temperatures in case of fire and therefore requires special Extinguishing measures. Suitable extinguishing agents are metal fire powder (fire class D) and dry sand. Unsuitable extinguishing media are water, foam and carbon dioxide.

There is a risk of explosion!



### **Hint! (Operating conditions)**

Due to its structural characteristics, the device is designed for indoor operation (IP20). Never expose the device to rain, moisture or liquids, as this can cause damage.

Vibrations, dust or sunlight can also lead to damage, avoid them!

The spark effect produces smoke, an odour nuisance and deposits on the floor due to precipitated particles. Therefore, always ensure adequate ventilation, especially in closed rooms.

Staub bzw. Rauch nicht einatmen, nicht in die Augen, auf die Haut oder die Kleidung gelangen lassen. Bei Gebrauch nicht essen, trinken oder rauchen. Verunreinigte Kleidung wechseln und gründlich waschen. Nach dem Gebrauch Hände waschen.



### **Hint! (Power supply)**

It is essential that you check that the device voltage matches your local mains voltage. It is highly recommended that you fuse your mains socket with a residual current circuit breaker (FI).

If you do not use your device for a longer period of time or carry out maintenance work, disconnect the device from the mains in order to minimize danger. The same applies to storm conditions such as thunderstorms, floods, etc.



### **Hint! (Error during data transmission)**

Never connect the DMX input or output to audio devices such as power amplifiers or mixing consoles!

DMX cables enable trouble-free operation and the highest possible transmission reliability of signal data. Do not use microphone cables!



### **Hint! (Condensation)**

To avoid condensation in the unit, the unit should adapt to the ambient temperature before commissioning.

**Hint! (Unwanted odours)**

A new product can sometimes lead to unwanted odours. This reaction is normal and disappears after a few minutes.

**Hint! (Matching granules)**

Always disconnect the unit from the mains before filling!

Do not fill in hot liquids!

Only use high-quality granulate recommended by your dealer. Other granules may cause damage. Do not mix any additives, such as oil, gas, perfumes, salts, etc., into the granulate.

**Matching granules:**

LIG0016966-000 - lightmaXX Powder VECTOR Spark Up!

Ideally, always fill the entire contents of a pack of granules into the filling opening of the device. If possible, store the partial quantities in the original packaging or in an airtight sealable container for later reuse. Store the granules in an airtight sealed container in a dry, well ventilated place with a temperature not exceeding 20° until reuse. Never store together with other substances with which a dangerous chemical reaction is possible.

The interior of the device must be cleaned of granulate residues and serviced at regular intervals.

**Symbols on device and packaging:**

The lightning flash symbol warns the user of uninsulated voltages and the risk of electric shock.



The exclamation mark symbol draws the user's attention to important maintains and operating instructions in the manual.



Only suitable for indoor use.



This symbol defines the minimum distance of the object to be illuminated.



Read the manual

**Please read and follow the warnings and recommendations carefully to ensure safe and trouble-free use.**

**Installation:**

Be sure to check the device for damage before use. Use the original packaging or a suitable transport or storage packaging to protect the product optimally from influences such as dust, moisture, etc. when not in use.

Always place the device on a stable surface. The device may only be operated in an upright position. Do not lay it on its side. The appliance has an automatic stop mechanism that prevents sparks from being emitted if the appliance is tilted by more than 45°.

Never point the outlet opening directly at people or open flames. Keep an appropriate safety distance of 1 meter from the audience and from heat-sensitive and highly flammable objects (e.g. insulation materials in ceilings, wooden and plastic surfaces, curtains).

## Congratulations on your new lightmaXX Vector Spark UP!

Thank you for choosing a **lightmaXX** product. Through efficient development and economical production, **lightmaXX** enables high quality products at a fantastic price.

Please read the instruction manual carefully to learn about all the features of this product and keep it for future use.

Have fun with your new product!

### Your lightmaXX Team

#### Guarantee:

The current general terms and guarantee conditions of the Music Store professional GmbH apply. You can view it at: [www.musicstore.de](http://www.musicstore.de)

If you have any questions or suggestions, please contact us:

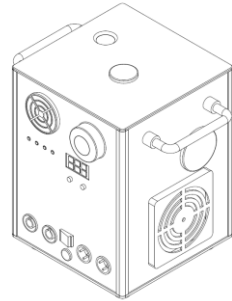

#### Music Store professional GmbH

Istanbulstr. 22-26  
51103 Köln  
Geschäftsführer: Michael Sauer  
WEEE-Reg.-Nr. DE 41617453

Tel: +49 221 8884-0  
Fax: +49 221 8884-2500  
[info@musicstore.de](mailto:info@musicstore.de)

#### Scope of delivery:

Content	Quantity
Spark Machine	1
Power Cord	1
Manual	1

#### Intended use:

The product **lightmaXX Vector Spark UP!** creates a spark effect by heating a special granulate. The device may only be operated for this purpose and in accordance with the operating instructions. Other purposes, as well as operation under other operating conditions, are expressly not intended and can lead to damage to property or personal injury! No liability is accepted for damage resulting from improper use.

It must be ensured that the device is operated exclusively by trained and competent users who are in full possession of their mental, physical and sensory abilities. The use of other persons is expressly only permitted at the request of a person responsible for their safety, who instructs or supervises the use.

**Set up:**

All connections of the device should be made before switching on. Only use high-quality cables that are as short as possible for the connections.

**Configuration of the DMX connector:**

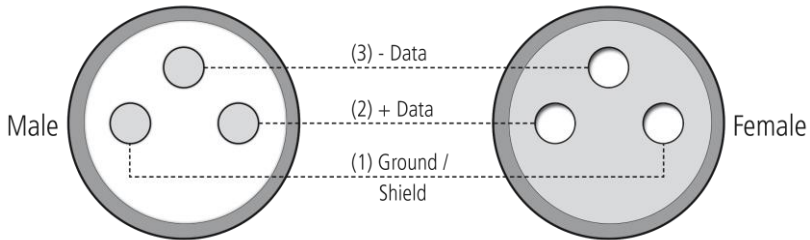

Resistance 120 ohm // ¼ w between pin 2 (DMX-) and pin 3 (DMX+) of the last fixture.

**Operating mode DMX:**

Connect the DMX input of your device to the DMX output of your DMX controller, your DMX software or the DMX output of a device already in your DMX line. Always use a DMX cable with a 110 Ohm resistor for this connection. Address the device according to your DMX configuration. The following table shows the respective DMX modes of the individual devices with the corresponding values and functions:

**2-Channel Mode:**

Channel	Value	Function	Display
1	000-010	Preheat function OFF	
	011-220	Emergency STOP	E57
	230-239	Cleaning mode	CLE
	240-255	Preheat function ON	
2	000-015	Spark Effect OFF	OFF
	016-063	Height 1 meter	F1
	064-111	Height 2 meter	F2
	112-158	Height 3 meter	F3
	159-207	Height 4 meter	F4
	208-255	Height 5 meter	F5

## Operating mode Remote:

The device can be remote controlled using the remote control included in the scope of delivery.



Button	Function
1	Fountain height 1
2	Fountain height 2
3	Fountain height 3
4	Fountain height 4
5	Short press: Stop heating Long press (3 sec.): disconnect Remote Control
6	Emergency Stop
7	Short press: Start heating Long press (3 sec.): connect Remote Control
8	Clear Powder

## Operation:

### Set up and fill in granulate:

Place the lightmaXX Vector Spark UP! on a flat and dry surface and fill the machine with the granulate provided. To do this, remove the lid of the filling opening and then fill in the contents of a bag of granulate. It is best to use a funnel for this. Then close the filling opening with the appropriate lid again.

### Start:

Connect the device to the mains via the Power Twist input using the power cable supplied with the device.

Further devices can be supplied with power via the Power Twist Out mains output. Always connect the Power Twist output with the Power Twist input of the next device until all devices are connected. A total of up to 6 devices can be connected.

### Switch on:

Switch the unit on with the power switch. The unit will now heat up for 5 minutes while the red status indicator "HEAT" lights up. The display to the right of the status displays and operating buttons shows the rising temperature during the heating phase. No sparks can yet be emitted during the heating phase.

As soon as the heating phase is complete, the green status display "READY" lights up and the unit is ready to emit sparks.

The unit can emit a fountain over a period of 30 seconds. After these 30 seconds the unit stops automatically. The ejection must be reactivated.

### Status display:

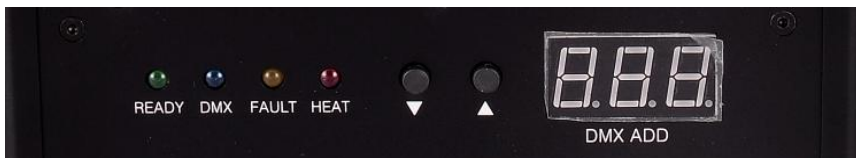

Display	Function
<b>READY</b>	The unit is ready for spark discharge
<b>DMX</b>	DMX mode activated
<b>FAULT</b>	Error message (see Troubleshooting)
<b>HEAT</b>	The unit heats up, no sparks



**Connections and controls:**

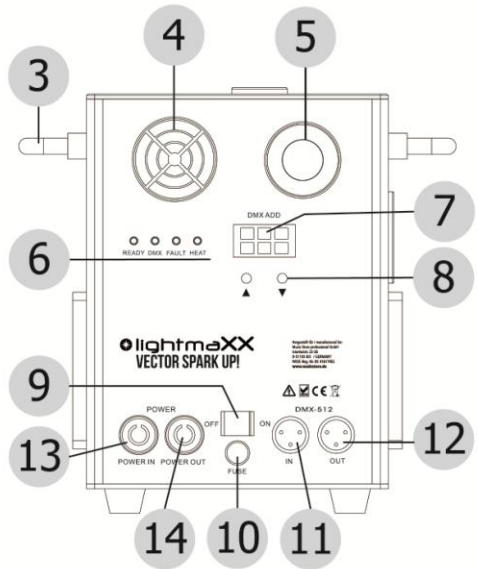
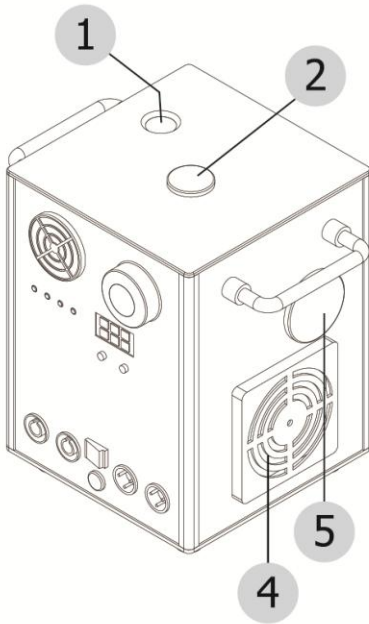

No.	Designation	No.	Designation
1	Outlet opening	8	Operating keys
2	Filling opening for the granulate with lid	9	On-/Off-Switch
3	Handle	10	Fuse
4	Fan	11	DMX Input (3-pole)
5	Removable cover for interior maintenance	12	DMX Output (3-pole)
6	Status displays	13	Power Twist Input
7	Display	14	Power Twist output for power supply of further devices (max. 6 devices)

**Specifications:**

Model	Vector Spark UP!
Power supply	AC 220-240V, 50Hz
Power consumption	650 Watt
Fuse	110V/10A, 220V/6A
Permitted Ambient temperature range	-5 - +45 °C
DMX Channels	2
Connections	DMX-Input/Output (3-pole) Power Twist Input/Output
Discharge height	1,9 meters
Discharge time	5 minutes
Material Case	Aluminium
Dimensions (L x W x H)	185 x 185 x 252 mm
Weight	5,9 kg



## Troubleshooting:

The following overview serves as an aid for quick troubleshooting. If you are unsure, contact the manufacturer, the dealer or the corresponding specialist personnel. Never open the device on your own!

Symptom	Troubleshooting
<b>E01</b> <b>Heating process failed</b>	Check whether the heat dissipation plate is defective. Replace the heat dissipation plate or the heating plate.
<b>E02</b> <b>Heating not controlled</b>	Replace heating plate
<b>E03</b> <b>Internal core temperature of the machine too high</b>	Check the fan. Stop the heating/operation and restart the appliance after 10 minutes
<b>E04</b> <b>Fan does not work</b>	Check whether a foreign object has fallen into the fan. Replace the fan.
<b>E05</b> <b>Temperature sensor has failed</b>	Replace the temperature sensor
<b>No function</b>	Check the mains connection and the fuse
<b>No reaction in DMX mode</b>	Check the cable connections
	Check your DMX address setting
	If available, try an alternative DMX controller
<b>No reaction in remote mode</b>	Change the battery in your remote control
	Ensure that the IR transmitter and receiver are at close and clear distances from each other

If the specified corrections have not led to success, please contact our service staff. The contact details can be found at [www.musicstore.de](http://www.musicstore.de)

## **Cleaning and maintenance:**

Regular cleaning of the device from impurities and dust increases the durability of the product. Always disconnect the appliance from the power supply before cleaning! Never clean the appliance wet! Avoid dust formation. Unavoidable dust deposits must be regularly removed with spark-free tools and collected in a lockable container.

Optical lenses should be cleaned with a dry microfiber cloth, optimizing light output. Ventilation grilles and openings should always be kept free of dust and dirt. Electrical component suitable compressed air sprays are recommended for this application.

### **Cleaning the lightmaXX Vector Spark UP! after use:**

At the end of use, perform the integrated cleaning function by radio remote control or DMX operation to clean the internal granulate residues.

Let the machine cool down first. Then turn the machine upside down and empty the granulate container completely. Finally, pick up the residue with non-sparking tools. You can store the residues in an airtight container for later reuse.

### **Storage of the granules:**

Protect the granulate from moisture and ignition sources. Do not smoke. Avoid dust formation. Always wear protective clothing, gloves and goggles. If possible, store the leftovers in their original packaging. Store the granules in an airtight sealed container in a dry, well ventilated place with a temperature not exceeding 20° until reuse. Never store together with other substances with which a dangerous chemical reaction is possible.

### **Cleaning of the interior:**

After 5 applications it is necessary to clean the interior in the area of the toothed belt, fan and the electronic unit from granulate residues. To do this, unscrew the cover of the housing and remove the residues. After cleaning, remount the cover before reusing the instrument.

## Environmental protection:

The company MUSIC STORE professional GmbH always strives to reduce the burden of packaging to a minimum. The use of environmentally friendly and recyclable materials is of fundamental importance to us. Please dispose of and recycle the packaging components after use properly.



### Disposal of packaging:

Ensure that paper packaging, plastic materials, etc. are separately recycled. Observe the corresponding disposal instructions on the packaging.



### Disposal of batteries:

Batteries do not belong in the garbage! Please keep batteries in accordance with the official collection points or disposal stations in accordance with the specifications.



### Disposal of your old device:

Do not dispose of the device with household waste! This device is subject to the WEEE Directive (Waste Electrical and Electronic Equipment) in its currently valid version.

The device will be disposed of by an approved waste disposal company or your local waste disposal office. The regulations valid in your country must be observed.



Hersteller: MUSIC STORE professional GmbH,  
Istanbulstraße 22-26,  
51103 Köln, Deutschland

