



# Desire Series by ETC

## D22, D40, D40XT, D60, D60X

### User Manual

Version 1.8.1

Part Number: 7410M1200-1.8.1 Rev: B  
Released: 2020-10

To view a list of ETC trademarks and patents, go to [etcconnect.com/ip](https://etcconnect.com/ip). All other trademarks, both marked and not marked, are the property of their respective owners.

ETC intends this document, whether printed or electronic, to be provided in its entirety.

# Table of Contents

	Introduction . . . . .	1
	Quick Setups . . . . .	1
	Vivid, Lustr+, Fire and Ice, Studio HD . . . . .	1
	Studio Daylight and Studio Tungsten . . . . .	1
	Models . . . . .	3
	Applications . . . . .	3
	Document Conventions . . . . .	3
	Notices . . . . .	3
	Typography Used in This Guide . . . . .	4
	Safety . . . . .	4
	Contacts . . . . .	5
<b>Chapter 1</b>	<b>Quick Start . . . . .</b>	<b>6</b>
	Install . . . . .	6
	Connect (D40, D40XT, D60, and D60X) . . . . .	6
	Connect (D22 Portable) . . . . .	6
	Connect (D22 Canopy and Track) . . . . .	6
	Focus . . . . .	7
	Set DMX Address . . . . .	7
	Quick Color (Vivid, Lustr+, Fire and Ice, Studio HD) . . . . .	7
	Quick Setups Menu . . . . .	8
	Quick Setups . . . . .	8
	Studio Quick Setup . . . . .	9
	Advanced Settings . . . . .	9
<b>Chapter 2</b>	<b>Installation and User Interface . . . . .</b>	<b>10</b>
	Specifications . . . . .	10
	Typical Power Consumption (D22) . . . . .	12
	Typical Power Consumption (D40 and D40XT) . . . . .	13
	Typical Power Consumption (D60) . . . . .	14
	Typical Power Consumption (D60X) . . . . .	15
	Note About LED Fixtures . . . . .	16

Color Rendering Index and Color Quality Scale Ratings . . . . .	16
Installation . . . . .	17
Mounting Hardware . . . . .	17
Aim Adjustment . . . . .	18
D40, D40XT, D60, D60X, D22 Portable . . . . .	18
D22 Canopy and Track . . . . .	19
Installation Clearances . . . . .	19
Cooling and Duty Cycle . . . . .	19
Dimensions and Hanging Clearances . . . . .	20
Safety Cable . . . . .	21
Fixture Weight . . . . .	21
Power and Data Cabling Requirements . . . . .	22
Power . . . . .	22
Data (D40, D40XT, D60, D60X) . . . . .	22
Data (D22) . . . . .	23
Connections . . . . .	24
D40, D60 Connections . . . . .	25
D40XT, D60X Connections . . . . .	25
D22 Portable DMX/RDM Connections . . . . .	25
Termination . . . . .	26
Indicator Lights . . . . .	26
DMX Addressing . . . . .	26
DMX Profiles . . . . .	27
Vivid, Lustr+, Fire and Ice, and Studio HD Profiles . . . . .	27
Studio Daylight and Studio Tungsten Profiles . . . . .	31
Fan Control (D60) . . . . .	31
DMX Footprints and Channel Mapping . . . . .	32
D22, D40, D40XT, D60 and D60X (Studio Tungsten and Daylight) . . . . .	32
D22 (Lustr+ and Studio HD) . . . . .	32
D40 (Vivid, Lustr+, Fire, Ice, Studio HD) . . . . .	33
D60 (Vivid, Lustr+, Fire, Ice, Studio HD) . . . . .	33
D60X (Vivid, Lustr+, Studio HD) . . . . .	33
Quick Color (Vivid, Lustr+, Fire and Ice, Studio HD) . . . . .	34
DMX Profile Tables . . . . .	34
Install Accessories . . . . .	38



<b>Chapter 3</b>	<b>Basic Menu Navigation . . . . .</b>	<b>39</b>
	User Interface Overview . . . . .	39
	LCD . . . . .	39
	Keypad . . . . .	40
	Keypad Lockout . . . . .	41
	Status Indicators . . . . .	41
	Screen Navigation . . . . .	41
	Status (Home) Screens . . . . .	42
	Menu Navigation . . . . .	43
<b>Chapter 4</b>	<b>Operation . . . . .</b>	<b>44</b>
	Home Screen Displays . . . . .	44
	Vivid, Lustr+, Fire and Ice, Studio HD . . . . .	44
	Studio Daylight and Studio Tungsten . . . . .	44
	Main Menu . . . . .	45
	DMX Start Address . . . . .	45
	Quick Setups . . . . .	46
	Advanced Settings . . . . .	46
	Advanced Menu . . . . .	46
	DMX Settings . . . . .	47
	LED Settings . . . . .	51
	Presets & Sequences . . . . .	55
	Diagnostics . . . . .	65
	Local Settings . . . . .	69
	Copy All Settings . . . . .	72
	Studio Settings . . . . .	72
	Vivid, Lustr+, Fire and Ice, Studio HD . . . . .	72
	Studio Daylight and Studio Tungsten . . . . .	75
	Configure D60X using RDM . . . . .	76
	Connect using Gadget II . . . . .	77
	Connect using a DMX/RDM Gateway . . . . .	78
	Configuration . . . . .	78
	Error Messages . . . . .	79
	Software Updates . . . . .	79
	ETC Technical Support . . . . .	79
	Routine Maintenance . . . . .	80

<b>Appendix A</b>	<b>Menu Flow Chart . . . . .</b>	<b>81</b>
	Home and Main Menus (Vivid, Lustr+, Fire and Ice, Studio HD) . . . . .	81
	Home and Main Menus (Studio Daylight and Studio Tungsten) . . . . .	82
	Advanced Menu (Vivid, Lustr+, Fire and Ice, Studio HD) . . . . .	83
	Advanced Menu (Studio Daylight and Studio Tungsten) . . . . .	84
	Presets (Vivid, Lustr+, Fire and Ice, Studio HD) . . . . .	85
	Presets Menu (Studio Daylight and Studio Tungsten) . . . . .	86
	Sequences and Quick Color Menus (Vivid, Lustr+, Fire and Ice, Studio HD) . . . . .	87
	Diagnostics Menu . . . . .	88
	Diagnostics Test . . . . .	89
	Diagnostics Recalibrate Fixture . . . . .	90
<b>Appendix B</b>	<b>RDM Commands . . . . .</b>	<b>91</b>

# Introduction

---

Congratulations on your purchase of a *Desire Series by ETC* product.

Desire's x7 Color System seven-hue technology produces a light and color quality that conventional LED systems cannot duplicate. This unique color system produces bright, broad-spectrum whites and intense colors equally well, rendering pigments, objects, and skin tones in a natural way.

Fire and Ice fixtures use elements of the x7 Color System for superior performance in deep saturated colors.

Studio Daylight and Studio Tungsten fixtures use high-output white LEDs for maximum brightness and efficacy. Studio Tungsten interacts very well with incandescent sources, while Studio Daylight easily replaces a variety of HMI lamps and natural sunlight.

## Quick Setups

You can use any one of the Quick Setups and fine-tune settings for either console operation via DMX protocol or stand-alone operation. For advanced users, an expanded user interface provides easy navigation to all settings and options.

### Vivid, Lustr+, Fire and Ice, Studio HD

Some of the options include:

- Multiple DMX profiles ranging from a simple 3-channel RGB profile to 8-channel native color and intensity control.
- Multiple dimming curve options.
- Preset colors and sequences for stand-alone operation.
- White point selection; white light and color behavior based on a specific color temperature white light such as 3200 K or 5600 K.
- Loss-of-data behavior options.
- Power regulation modes; three output options that offer a choice between maximum light output for lower duty cycles and maximum thermal stability and output consistency for higher duty cycles.

### Studio Daylight and Studio Tungsten

Some of the options include:

- Multiple dimming curve options.
- Presets and sequences for stand-alone operation.
- Strobe.
- Loss-of-data behavior options.
- Power regulation modes; three output options that offer a choice between maximum light output for lower duty cycles and maximum thermal stability and output consistency for higher duty cycles.

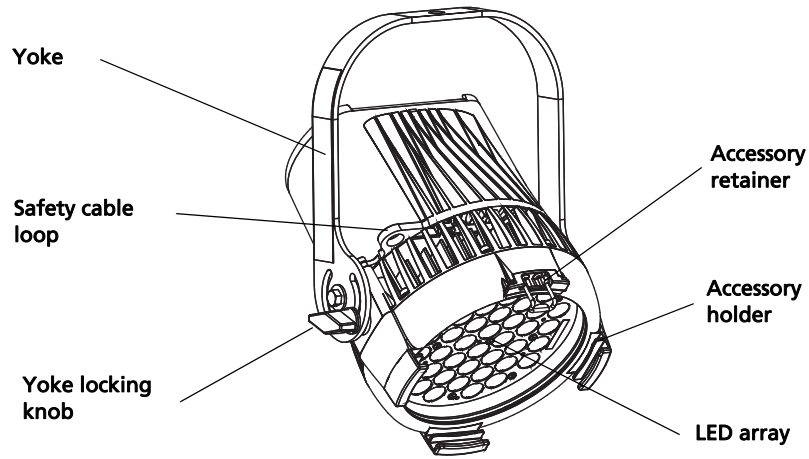

Figure-1.1 Components of a D40 Fixture

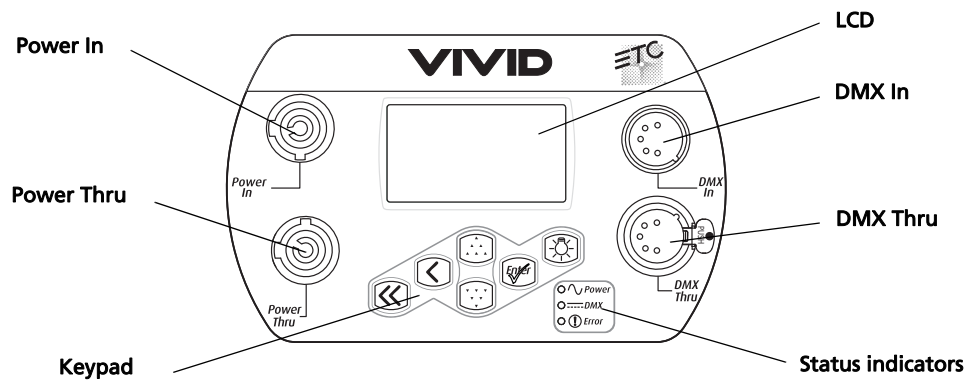

Figure-1.2 Components of the Rear Panel. D40 and D60 shown.

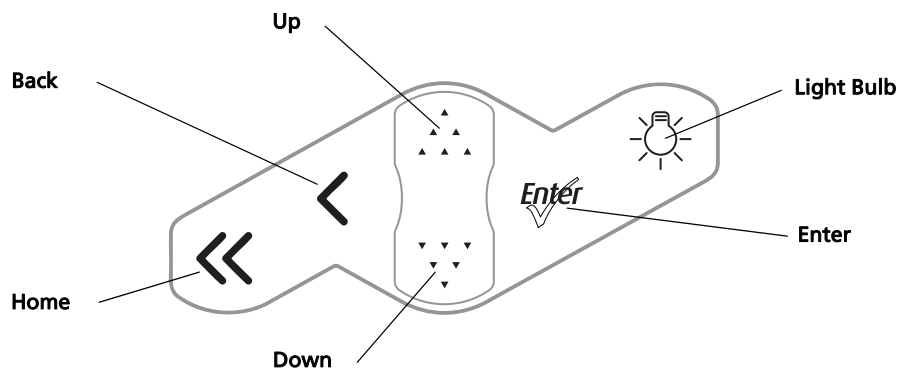

Figure-1.3 Keypad Button Functions

For more information about the user interface, see [User Interface Overview](#) on [page 39](#).

## Models

Each member of the Desire Series product line is unique and optimized for a specific lighting task. All fixtures feature narrow optics for the longest throws.

### Vivid (D40, D40XT, D60, D60X)

- Full 7-color x7 LED array
- Optimized for high-output deep pastels and strong saturated colors—an all-around workhorse for vibrant color washes

### Lustr+ (D22, D40, D40XT, D60, D60X)

- Specialized x7 LED array with 6 colors plus white
- Broad-spectrum color optimized for the best white and light tints across the entire white and pastel range
- Beautifully illuminates skin tones and other objects—ideal for theatrical lighting

### Fire and Ice (D40, D40XT, D60)

- Optimized for saturated colors at the red end (Fire) or blue end (Ice) of the spectrum
- Strongest output for high-intensity washes and theatrical environments

### Studio HD (D22, D40, D40XT, D60, D60X)

- Precise mix of warm white and cool white LEDs plus additional strategic colors for fuller spectral power
- Continuously variable color temperature white light
- Extreme CRI and high-definition illumination of skin tones from 2700 K to 6500 K

### Studio Daylight (D22, D40, D40XT, D60, D60X)

- 5,700 K nominal correlated color temperature
- 70 CRI typical

### Studio Tungsten (D22, D40, D40XT, D60, D60X)

- 3,000 K nominal correlated color temperature
- 85 CRI typical



- WARNING:**
- Do not link more than nine fixtures when using Power Thru (non-dimming, 100 to 240 VAC, 50/60 Hz). Power Thru is not available on all Desire Series fixtures.
  - Up to 32 devices can be daisy-chained together per data run.
- 

## Applications

- Theaters
- Studios
- Schools
- Houses of worship
- Hotels
- Convention centers
- Theme parks
- Museums
- Temporary events
- Outdoor (D40XT and D60X only)

## Document Conventions

### Notices

Throughout this manual, the following are used to alert you to notes and safety notices.



**Note:** *Notes are helpful hints and information that is supplemental to the main text.*

---



**CAUTION:** *A Caution statement indicates situations where there may be undefined or unwanted consequences of an action, potential for data loss or an equipment problem.*

---



**WARNING:** A Warning statement indicates situations where damage may occur, people may be harmed, or there are serious or dangerous consequences of an action.

---



**WARNING:** RISK OF ELECTRIC SHOCK! This warning statement indicates situations where there is a risk of electric shock.

---

## Typography Used in This Guide

Menu items and commands you must perform are indicated in **bold text**. Keypad buttons are indicated in bold **[brackets]**. Menu selections or commands appear in **bold**. For example:

Press [**▼▼▼**] to select **Sequences** and then press [**Enter**].

## Safety

The Desire series fixtures are intended for professional use only. Read entire User Manual before using equipment.

---



- WARNING:**
- Do not mount the Desire series fixture on or near a flammable surface.
  - Use the D22, D40, and D60 fixtures in dry locations only, where humidity does not exceed 90 percent (non-condensing). These fixtures are not intended for outdoor use. (Only the D40XT and D60X are approved for outdoor use.)
  - Mount and support the fixture only by the primary suspension holes in the yoke or floor standing yoke.
  - Suspend the fixture from a suitable structure using only the hardware rated for the weight of the fixture.
  - In addition to primary suspension, attach a safety cable (ETC Model 400SC or other approved safety cable or device) to the fixture housing. Appropriate attachment point (hole) is provided in the protruding tab on the fixture housing.
  - Disconnect the unit from power and from DMX before all cleaning and maintenance.
  - Maximum recommended ambient operating temperature:  $T_a=40^{\circ}\text{C}$  (104°F)
  - Maximum anticipated external surface temperature:  $T_{\text{max}}=80^{\circ}\text{C}$  (158°F)
  - External temperature after 5 minutes of full-brightness operation and 23°C (74°F) ambient: 38°C (100°F)
  - External Temperature (steady state achieved) at 23°C (74°F): 70°C (158°F)
-

## Contacts

If you are having difficulties and your problem is not addressed by this document, try the ETC support website at [support.etconnect.com](https://support.etconnect.com) or the main ETC website at [etconnect.com](https://etconnect.com). If none of these resources are sufficient, contact ETC Technical Services directly at one of the offices identified below. Emergency service is available from all ETC offices outside of regular business hours.

When calling for help, please have the following information handy:

- Product model and serial number (located on back panel)
- Dimmer manufacturer and installation type
- Other components in your system (Unison, other consoles, etc.)

### Americas

ETC, Inc.  
Technical Services Department  
3031 Pleasant View Road  
Middleton, WI 53562  
800-775-4382 (USA, toll-free)  
+1-608 831-4116  
[service@etconnect.com](mailto:service@etconnect.com)

### Asia

ETC Asia  
Technical Services Department  
Room 1801, 18/F  
Tower 1, Phase 1 Enterprise Square  
9 Sheung Yuet Road  
Kowloon Bay, Kowloon, Hong Kong  
+852 2799 1220  
[techserv-asia@etconnect.com](mailto:techserv-asia@etconnect.com)

### France

ETC France  
Zone Urbaparc -  
Bâtiment E  
6 Boulevard de la Libération  
Saint-Denis, 93200  
+33 1 4243 3535  
[techservltd@etconnect.com](mailto:techservltd@etconnect.com)

### United Kingdom

ETC Ltd - UK  
Technical Services Department  
26-28 Victoria Industrial Estate  
Victoria Road,  
London W3 6UU England  
+44 (0)20 8896 1000  
[techservltd@etconnect.com](mailto:techservltd@etconnect.com)

### Germany

ETC GmbH  
Technical Services Department  
Ohmstrasse 3  
83607 Holzkirchen, Germany  
+49 (80 24) 47 00-0  
[techserv-germany@etconnect.com](mailto:techserv-germany@etconnect.com)

# Chapter 1

## Quick Start

---

This section details the steps for a quick fixture setup. For more comprehensive information, see [Operation](#) on [page 44](#).

### Install

- 1: Hang or mount the fixture using the provided hardware and approved hardware accessories.
- 2: Attach an approved safety cable when applicable.
- 3: Insert secondary lenses with the smooth side out, if desired.
- 4: Insert additional accessories (top hat, egg crate, etc.) into the holder, if desired.

### Connect (D40, D40XT, D60, and D60X)

- 1: Attach the power cable to the Power In connector.
- 2: Attach 5-pin XLR cable to the DMX In connector (if using external control).
- 3: Plug the power cable into AC power (100 to 240 VAC, 50/60 Hz) on a non-dimming circuit.
- 4: Plug the XLR cable (if using) into the DMX source or data daisy-chain.
- 5: Link additional fixtures via the Power Out and DMX Out connectors using the following guidelines.
  - No more than nine total D40, D60X, or D40XT fixtures on Power Thru.
  - Up to 32 device loads on the DMX daisy-chain.

### Connect (D22 Portable)

- 1: Attach 5-pin XLR cable to the DMX In connector (if using external control).
- 2: Plug the power cable into AC power (100 to 240 VAC, 50/60 Hz) on a non-dimming circuit.
- 3: Plug the XLR cable (if using) into the DMX source or data daisy-chain.



**WARNING:** Do not link more than nine fixtures when using Power Thru (non-dimming, 100 to 240 VAC, 50/60 Hz). Power Thru is not available on all Desire Series fixtures.

Up to 32 devices can be daisy-chained together per data run.

---

### Connect (D22 Canopy and Track)

For installation and connection information, refer to *Desire Series D22 Installation Guide*. ETC manuals are available for download at [etconnect.com](http://etconnect.com).



## Focus

- 1: With power supplied, wait for the fixture to boot up. This will take approximately ten seconds.
- 2: Press [] to open the **Presets & Sequences** menu.
- 3: Select **Focus** and then press []. This turns on the LED array to enable focusing.
- 4: Adjust the fixture's position as needed.
- 5: When focusing is complete, press [] to restore the fixture to its original preset.
- 6: Select [] to return to the home screen.

For information about the user interface, see [User Interface Overview](#) on [page 39](#).

## Set DMX Address

- 1: From the main screen, press [] to open the **Main Menu**.
- 2: On the **Main Menu**, scroll to **DMX Start Address** and then press [].
- 3: Use [] or [] to scroll to the desired **address**.
- 4: Press [] to select the **address** number.
- 5: Press [] to return to the home screen.

A DMX address is not required if using stand-alone or master/slave control.

## Quick Color (Vivid, Lustr+, Fire and Ice, Studio HD)

Quick Color allows you to easily select a color and its intensity from a predefined menu. This feature overrides any presets or sequences previously selected and is only available when there is no external DMX signal to the fixture. For a list of available colors, see [Presets \(Vivid, Lustr+, Fire and Ice, Studio HD\)](#) on [page 56](#).



---

**Note:** *Exiting the Quick Color menu will return the fixture to the state it was in prior to entering the menu.*

---

- 1: Press the [] to access the **Presets and Sequences** screen.
- 2: Scroll to **Quick Color** within the **Presets and Sequences** screen.
- 3: Press [].
- 4: Scroll to **Color** and press [].
- 5: Press [] or [] to select the desired color
- 6: Press [] to commit the selection.
- 7: Scroll to **Intensity** and press [].
- 8: Press and hold [] or [] to adjust the fixture's intensity.
- 9: Press [] to commit the selection.
  - To set the Intensity to 0, press []. Pressing [] a second time will return the fixture to its previously set intensity.
  - If power to the fixture is lost while in Quick Color mode, the fixture will return to the Quick Color menu when power is restored.

## Quick Setups Menu

Various pre-programmed combinations of operational settings are available to quickly get you started. These settings are specifically created for different situations and are easily accessible on the fixture's user interface. Individual settings within each quick setup can be accessed via the Advanced menu in order to take advantage of all the possible control features.

### Quick Setups

1: On the **Main Menu**, scroll to **Quick Setups**.

2: Press **[Enter]**.

3: Scroll to the desired setup and then press **[Enter]**.

An asterisk (\*) next to the setup name indicates that setup is active.











4: Press **[Enter]** to return to the home screen.

Quick Setup	Description	Profile	Features
<b>General</b>	<ul style="list-style-type: none"> <li>• For general lighting</li> <li>• All-purpose settings for most lighting applications</li> <li>• The default setup for the Lustr+ and Series 2 Lustr</li> </ul>	Direct control	<ul style="list-style-type: none"> <li>• Standard dimming curve</li> <li>• Regulated output for brightness consistency</li> <li>• Individual color channels plus master intensity control</li> <li>• Allows for native color space crossfades</li> </ul>
<b>Stage</b>	<ul style="list-style-type: none"> <li>• For theatrical lighting</li> <li>• Tungsten-like performance and precise color-control</li> <li>• Uses the most DMX channels of all quick setups</li> </ul>	HSI Plus Seven enabled	<ul style="list-style-type: none"> <li>• Incandescent dimming curve</li> <li>• Regulated output for brightness consistency</li> <li>• White point: 3200 K</li> </ul>
<b>XT Arch</b>	<ul style="list-style-type: none"> <li>• Longevity and reliability in applications with limited access and extreme environments</li> <li>• High degree of output consistency and protection against temperature swings</li> </ul>	HSI	<ul style="list-style-type: none"> <li>• Standard dimming curve</li> <li>• Protected output for high-heat environments</li> <li>• Reduced overall brightness</li> <li>• White point: 3200 K</li> </ul>
<b>High Impact</b>	<ul style="list-style-type: none"> <li>• For concerts and high impact lighting</li> <li>• Enables quickest response, simple RGB control and strobe channel for maximum effect usage</li> </ul>	RGB	<ul style="list-style-type: none"> <li>• Quick dimming response</li> <li>• Boosted output for maximum intensity</li> <li>• Reduced consistency of output</li> <li>• White point: 5600 K</li> </ul>



Quick Setup	Description	Profile	Features
Studio	<ul style="list-style-type: none"> <li>• For video or film lighting</li> <li>• Enables quick, comprehensive control of white light via DMX or the fixture's onboard user interface</li> <li>• High-quality white-light output</li> </ul>	Studio	<ul style="list-style-type: none"> <li>• Linear dimming curve</li> <li>• Regulated output for brightness consistency</li> <li>• Variable white point 2700–6500 K</li> <li>• Variable + or – green (tint) with the Vivid, Lustr+, Fire and Ice, Studio HD</li> </ul>
	<p>The Studio Quick Setup is operational in all fixtures for excellent white light performance. It is the default setting for Series 2 Daylight HD, Series 2 Tungsten HD and Studio HD fixtures. In addition, Studio Quick Setup enables stand-alone operation from the User Interface on the back of the fixture if no console is present.</p> <p>For more information, see <a href="#">Studio Settings</a> on <a href="#">page 72</a>.</p>		

## Studio Quick Setup

From the home screen:

- To adjust the **Intensity**, press [] or []. The range is 0 to 100%.
- To adjust the **White Point**, press [] or []. The range is 2700 to 6500 K.
- To adjust the **Tint**, press [] & [] or []. [] increases magenta and [] increases green.
- To return to the Main Menu, press [].

## Advanced Settings

- 1: From the **Main Menu** press [] to scroll to **Advanced Settings**.
- 2: Press [].
- 3: Access the individual settings via additional menus.
- 4: Press [] to return to the home screen.

Once you are familiar with your Desire fixture, you may alter any of the numerous individual settings from the Advanced Settings menu. For more information, see [Advanced Menu](#) on [page 46](#).

# Chapter 2

## Installation and User Interface

---

### Specifications

#### Physical

---

- Rugged die-cast aluminum construction
- Easy-access slots for secondary lenses and standard 7.5 inch PAR accessories (D40 and D40XT)
- 5.5 inch accessories (D22)
- 8.875 inch accessories (D60 and D60X)
- Advanced thermal management systems for long LED life
- Ambient operating temperature:
  - D22: 0°C–40°C (32°F–104°F)
  - D40XT and D60X: -20°C–40°C (-4°F–104°F)
  - D40, and D60: 0°C–40°C (32°F–104°F)
- Continuous operation at 40°C (104°F)
- D40XT and D60X rated IP66 for exterior use
- Hanging yoke standard. Optional yoke and floor stand available
- D22, D40, D40XT, and D60X models feature noise-free, fan-less convection cooling for acoustically sensitive installations
- Available in black (standard), white (optional), silver, or custom colors (contact factory)
- D60 model features ultra-quiet cooling fan for use in high ambient temperature situations
- See [Fixture Weight](#) on [page 21](#)
- See [Dimensions and Hanging Clearances](#) on [page 20](#)

#### Electrical

---

- 100 V to 240 V 50/60 Hz universal power input
- Up to nine D60, or D60X fixtures (15A max) may be linked on Power Thru
- Up to ten D40 or D40XT (15A max) may be linked on Power Thru
- D22 has 1.8 m flying lead with an Edison connector, no thru
- D40 and D60 models include Neutrik® powerCON® in and thru connectors
- 5-foot Neutrik powerCON to bare-end power input lead or 6-ft parallel blade U-ground (Edison) connector (D40, D60)
- Optional 5-foot powerCON to 20A two pin and ground (stage pin) or grounded 20A twistlock connector (excluding D40XT and D60X)
- D40XT and D60X model includes a 5-foot power cable with waterproof IP66 connector
- **Note:** D40XT has optional power leads available including Molex to bare end. Please see the D40XT datasheet for more information.
- Requires power from non-dimmable source

#### LEDs

---

- 22 Luxeon® Rebel™ ES LED emitters (D22 Studio Daylight and Studio Tungsten)
- 40 Luxeon Rebel LED emitters (D40 and D40XT Vivid, Lustr+, Fire and Ice, Studio HD)
- 22 Luxeon Rebel LED emitters (D22 Lustr+ and Studio HD)
- 60 Luxeon Rebel LED emitters (D60 Vivid, Lustr+, Fire and Ice, Studio HD, and D60X)
- 40 Luxeon Rebel ES LED emitters (D40 and D40XT Studio Daylight and Studio Tungsten)
- 60 Luxeon Rebel ES LED emitters (D60 and D60X Studio Daylight and Studio Tungsten)
- See [Note About LED Fixtures](#) on [page 16](#)
- 50,000-hour LED life

## Optical

---

- Tight primary field angle of 17° (Vivid, Lustr+, Fire and Ice, Studio HD)
- Tight primary field angle of 24° (Studio Daylight and Studio Tungsten)
- Combine linear lenses for desired beam spread
- Secondary lenses available for multiple beam spread options including round, oblong, and linear patterns
- Slots for secondary lenses

## Color

---

- Specialized capabilities from different LED array options based on x7 color-mixing expertise:  
Vivid: Optimized for strong, saturated colors at maximum brightness  
Lustr+: x7 Color System array with a high-intensity white LED for an ideal theatrical wash light  
Full range color, with an emphasis on lighter colors and white  
Fire and Ice: Optimized for high-intensity saturated colors in either the warm, red end of the spectrum (Fire) or the cool, blue end of the spectrum (Ice) (not available with D60X fixtures)  
Studio HD: Optimized for variable color temperature white light
- Interacts seamlessly with conventional sources
- Achieves excellent 3200° or any other Correlated Color Temperature white light from 2000 to 10,000°K (except Fire or Ice) (CCT adjustment not available on Studio Daylight and Studio Tungsten)
- Beautifully illuminates skin tones and other objects
- Deeply saturated colors across an exceptionally wide gamut

## Control

---

- DMX512-A compliant
- DMX in and thru via 5-pin XLR connectors (D40, D40XT, D60, D60X)
- DMX in and thru via 5-pin XLR connectors (Portable) or DMX termination board (Canopy). DMX in via Eutrac MultiAdapter track adapter (Track). (D22)
- Onboard user interface with a high-resolution LCD (not available with D60X)
- Optional DMX-based fan control (D60 only) for predictable noise levels
- Optional strobe channel
- Stand-alone, studio stand-alone, and console-free presets and sequences
- Master/slave mode
- Multiple profile options for different levels of control
- 15-bit virtual dimming engine for smooth, high-quality theatrical fades
- See [DMX Addressing](#) on [page 26](#)

## Typical Power Consumption (D22)

### *Lustr+*

	<b>100V</b>	<b>120V</b>	<b>230V</b>
Idle Power / Current	7.8W / 0.111A	7.6W / 0.111A	7.4W / 0.094A
100% Boost Power / Current	56.8W / 0.578A	56.5W / 0.475A	55.1W / 0.288A

### *Studio Daylight*

	<b>100V</b>	<b>120V</b>	<b>230V</b>
Idle Power / Current	7.3W / 0.093A	7.2W / 0.091A	7.3W / 0.124A
100% Boost Power / Current	55.2W / 0.556A	55W / 0.462A	53.8W / 0.268A

### *Studio Tungsten*

	<b>100V</b>	<b>120V</b>	<b>230V</b>
Idle Power / Current	7.6W / 0.011A	7.6W / 0.011A	7.2W / 0.094A
100% Boost Power / Current	52.4W / 0.532A	51.8W / 0.445A	50.9W / 0.276A

### *Studio HD*

	<b>100V</b>	<b>120V</b>	<b>230V</b>
Idle Power / Current	6.7W / 0.095A	6.7W / 0.098A	6.7W / 0.118A
100% Boost Power / Current	55W / 0.555A	54.6W / 0.464A	53.3W / 0.271A

## Typical Power Consumption (D40 and D40XT)

### *Vivid*

	<b>100V</b>	<b>120V</b>	<b>240V</b>
Idle Power / Current	10.5W / 0.135A	11W / 0.098A	12.7W / 0.078A
100% Boost Power / Current	102W / 1.12A	98W / 0.82A	95.6W / 0.403A

### *Lustr+*

	<b>100V</b>	<b>120V</b>	<b>240V</b>
Idle Power / Current	10.3W / 0.125A	10.5W / 0.094A	12.2W / 0.074A
100% Boost Power / Current	104W / 1.16A	102W / 0.861A	99.7W / 0.418A

### *Fire*

	<b>100V</b>	<b>120V</b>	<b>240V</b>
Idle Power / Current	10.5W / 0.125A	10.8W / 0.096A	12.5W / 0.076A
100% Boost Power / Current	91.2W / 1.02A	88.2W / 0.74A	87.2W / 0.369A

### *Ice*

	<b>100V</b>	<b>120V</b>	<b>240V</b>
Idle Power / Current	11.0W / 0.123A	11.2W / 0.099A	12.8W / 0.077A
100% Boost Power / Current	104.2W / 1.17A	102.2W / 0.867A	99.5W / 0.42A

### *Studio HD*

	<b>100V</b>	<b>120V</b>	<b>240V</b>
Idle Power / Current	11.1W / 0.134A	11W / 0.097A	12.8W / 0.077A
100% Boost Power / Current	106.2W / 1.19A	103.5W / 0.883A	101.3W / 0.426A

### *Studio Daylight*

	<b>100V</b>	<b>120V</b>	<b>240V</b>
Idle Power / Current	10.6W / 0.123A	10.6W / 0.095A	12.4W / 0.076A
100% Boost Power / Current	105.1W / 1.12A	103.3W / 0.878A	100.8W / 0.424A

### *Studio Tungsten*

	<b>100V</b>	<b>120V</b>	<b>240V</b>
Idle Power / Current	10W / 0.111A	10.1W / 0.093A	11.9W / 0.075A
100% Boost Power / Current	104W / 1.05A	103.1W / 0.872A	100.3W / 0.422A

## Typical Power Consumption (D60)

### *Vivid*

	100V	120V	240V
Idle Power / Current	7.6W / 0.083A	7.7W / 0.083A	9.2W / 0.087A
100% Boost Power / Current	139W / 1.41A	136.1W / 1.15A	130.3W / 0.549A

### *Lustr+*

	100V	120V	240V
Idle Power / Current	7.3W / 0.1A	7.4W / 0.77A	9W / 0.086A
100% Boost Power / Current	143W / 1.46A	140.1W / 1.21A	135.1W / 0.57A

### *Fire*

	100V	120V	240V
Idle Power / Current	7.9W / 0.105A	7.9W / 0.086A	9.4W / 0.089A
100% Boost Power / Current	129W / 1.35A	126.5W / 1.35A	122.7W / 0.52A

### *Ice*

	100V	120V	240V
Idle Power / Current	7.3W / 0.095A	7.4W / 0.081A	9W / 0.085A
100% Boost Power / Current	148.5W / 1.53A	147W / 1.28A	140.2W / 0.592A

### *Studio HD*

	100V	120V	240V
Idle Power / Current	7.2W / 0.086A	7.3W / 0.082A	8.9W / 0.086A
100% Boost Power / Current	146W / 1.5A	143.7W / 1.24A	138.2W / 0.58A

### *Studio Daylight*

	100V	120V	240V
Idle Power (W)	7.5W / 0.09A	7.6W / 0.084A	9.3W / 0.089A
100% Boost Power (W)	145.5W / 1.48A	142.8W / 1.22A	136W / 0.573A

### *Studio Tungsten*

	100V	120V	240V
Idle Power (W)	7.4W / 0.088A	7.5W / 0.083A	9.1W / 0.088A
100% Boost Power (W)	145.8W / 1.49A	143.3W / 1.23A	137.1W / 0.577A



## Typical Power Consumption (D60X)

### *Vivid*

	<b>100V</b>	<b>120V</b>	<b>240V</b>
Idle Power / Current	4.2W / 0.08A	4.3W / 0.075A	4.1W / 0.067A
100% Boost Power / Current	117.9W / 1.19A	118W / 1A	115.6W / 0.526A

### *Lustr+*

	<b>100V</b>	<b>120V</b>	<b>240V</b>
Idle Power / Current	4.12W / 0.8A	4.32W / 0.074A	3.85W / 0.063A
100% Boost Power / Current	126W / 1.27A	126W / 1.06	123W / 0.55

### *Studio HD*

	<b>100V</b>	<b>120V</b>	<b>240V</b>
Idle Power / Current	4.2W / 0.08A	4.3W / 0.76 A	4.3W / 0.068A
100% Boost Power / Current	125.1W / 1.26A	124.7W / 1.05A	122.5W / 0.552A

### *Studio Daylight*

	<b>100V</b>	<b>120V</b>	<b>240V</b>
Idle Power / Current	4.2W / 0.08A	4.3W / 0.76 A	4.2W / 0.068A
100% Boost Power / Current	125.1W / 1.26A	124.7W / 1.05A	122.5W / 0.552A

### *Studio Tungsten*

	<b>100V</b>	<b>120V</b>	<b>240V</b>
Idle Power / Current	4.3W / 0.08A	4.2W / 0.073A	4.2W / 0.065A
100% Boost Power / Current	124.4W / 1.25A	123.7W / 1.04A	121.2W / 0.545A

## Note About LED Fixtures

All LED sources experience some lessening of light output and some color shift over time. Desire Series fixtures have complex thermal management systems to minimize these changes. With typical usage, a Desire fixture will still achieve at least 70% of its initial output after 50,000 hours of use (B50, L70). In individual situations, LEDs will be used for different durations and different levels. This can eventually lead to minor alterations in color performance, necessitating slight adjustment to presets, cues, or programs.

All LEDs may exhibit a slight shift in output as they rise to full operating temperature. Desire Series fixtures allow the selection of different power settings in order to balance the competing requirements of thermal stability and brightness. Depending on the selected setting, changes in output as fixtures warm up may or may not be visible to the eye.

## Color Rendering Index and Color Quality Scale Ratings

Desire fixtures are evaluated for Color Rendering Index (CRI) and Color Quality Scale (CQS) performance using measured output spectrum and optimized mix solutions for a best spectral match to black body sources at 3200 K and 5600 K. Color fidelity is also measured. These numbers may fluctuate slightly from fixture to fixture. This is a normal characteristic of white LEDs, and this kind of variation is highly unlikely to be apparent in most applications. The performance is the same for all fixture versions.

Fixture	CRI	CQS	Color Fidelity	TLCI	Duv
Vivid at 3200 K	87	89	89	65	0.000
Vivid at 5600 K	90	92	92	74	0.000
Lustr+ at 3200 K	86	88	88	66	0.000
Lustr+ at 5600 K	93	92	90	86	0.000
Studio HD at 3200 K	89	90	91	85	0.000
Studio HD at 5600 K	92	94	94	91	0.000
Studio Tungsten at 3000 K	86	86	86	56	0.001
Studio Daylight at 5600 K	71	70	69	43	0.001

Desire luminaires provide excellent color rendering, particularly the color-mixing versions. A Duv rating of 0.000 indicates that the color mix used was exactly on the black body line, with no green or magenta tint.

Studio Daylight and Studio Tungsten fixtures use only white-type LEDs at a fixed color temperature in order to maximize output and efficacy.

# Installation

## Mounting Hardware

Four options are available for mounting Desire fixtures.

- Yoke with C-clamp
- Floor stand
- Canopy (D22)
- Track mount (D22)

### *Installing the Floor Stand*

The floor standing yoke assembly replaces the included standard yoke so that the fixture can be placed on a floor and tilted to the desired angle.

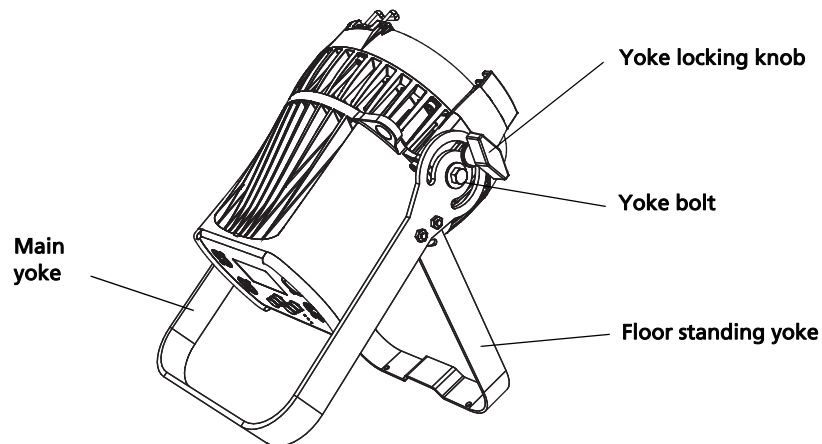

Figure-2.1 Fixture with Floor Stand

- 1: Remove the yoke locking knob with the flat washer.
- 2: Remove the yoke bolts and flat washers that attach the yoke on each side of the fixture.
- 3: Attach the yoke and floor standing yoke assembly to the fixture with the two yoke bolts and two flat washers.
- 4: Insert the yoke locking knob and flat washer and tighten.

### *Installing D22 Canopy and Track*

For detailed installation information, see the *Desire Series D22 Installation Guide*. ETC manuals are available for download at [etcconnect.com](http://etcconnect.com).

## Aim Adjustment

### D40, D40XT, D60, D60X, D22 Portable

The fixture can be tilted up and down and rotated (panned) to aim the light where it is needed. The adjustment is the same for the yoke or floor stand. To help aim the fixture, you can turn it on without connecting to DMX control or enabling a preset. For more information, see [Focus](#) on [page 55](#).

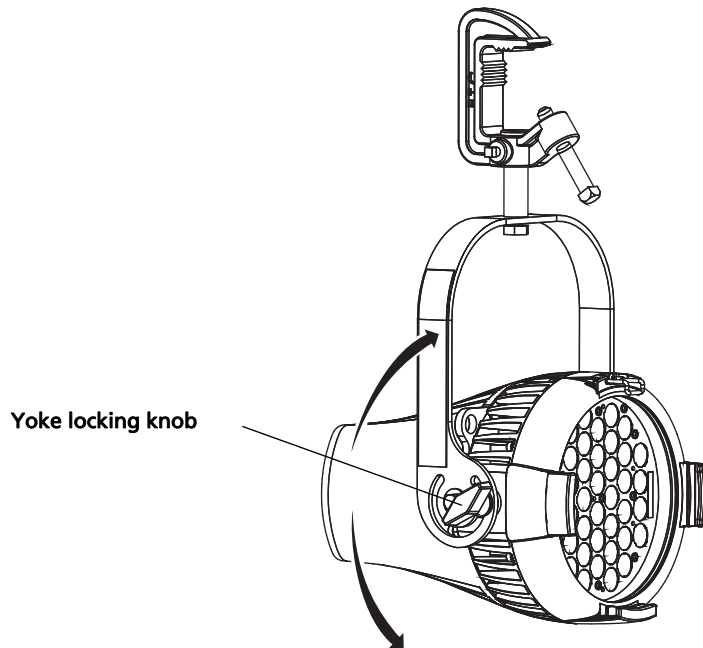

Figure-2.2 Tilting the Fixture on a Yoke

### ***Turn On the Fixture***

- 1: Apply power to the fixture.
- 2: On the back of the fixture press [].
- 3: With **Focus** selected, press [].

### ***Adjust the Tilt***

- 1: Loosen the yoke locking knob. **Do not** remove the knob.
- 2: Tilt the fixture to the desired angle.
- 3: Tighten the yoke locking knob.

### ***Adjust the Pan***

The pan is adjusted at the hanging clamp. Please consult the clamp manufacturer's documentation for instructions on loosening and rotating the yoke at the clamp.



---

**WARNING:** The safety cable (or other approved safety device) must be securely attached to the safety cable loop before loosening the clamp.

---

## D22 Canopy and Track

The Portable and Track mounted fixtures can tilted up and down and panned to aim the light where it is needed.

- 1: Pan the fixture to the desired position. The fixture is prevented from rotating completely around to protect the wiring.
- 2: To adjust the tilt, loosen the yoke locking knob. **Do not** remove the knob. Refer to <Blue>Figure-2.2.
- 3: Tilt the fixture to the desired angle.
- 4: Tighten the yoke locking knob.

## Installation Clearances

### Cooling and Duty Cycle

Desire D22, D40, and D60X Series fixtures are convection cooled and can operate all channels at full power continuously in ambient temperatures up to 40°C (104°F). The Desire D60 is equipped with a cooling fan, which is automatically controlled.

If ambient conditions exceed 40°C (104°F) or fail to allow sufficient airflow over a long period of time, the fixtures may shut down and remain off until they return to a safe operating temperature. The fixtures provide two methods to indicate over temperature that can be set up on the Local Settings menu. The over temperature indicators are:

- **Visible:** The LED array glows in a dull, low intensity with only some emitters illuminated, the LCD backlight is turned on, the LCD displays Overtemp Activated, and the Error Indicator light turns on.
- **Dark:** The LED array turns off and the LCD displays Overtemp Activated. The LCD backlight is not turned on.



### **CAUTION:** *Duty Cycle*

*Operating the fixtures in higher ambient temperatures or low-airflow situations may cause the power supply to shut down. Following a cool-down period, the power supply will automatically reset and the fixture will return to operation.*

*It is good practice to power down any device with onboard electronics to limit unnecessary wear on the devices and eliminate residual use of electricity. When not in use, Desire fixtures should be powered down by disconnecting from power either at the breaker or by unplugging.*

---

LED life is adversely affected by high-temperature operation. When operating under elevated ambient temperatures, avoid turning all channels to 100% for extended periods, such as channel checks or focusing.

## Dimensions and Hanging Clearances

Use the following dimensions to allow proper clearances around the fixture. Allow additional space for cables.

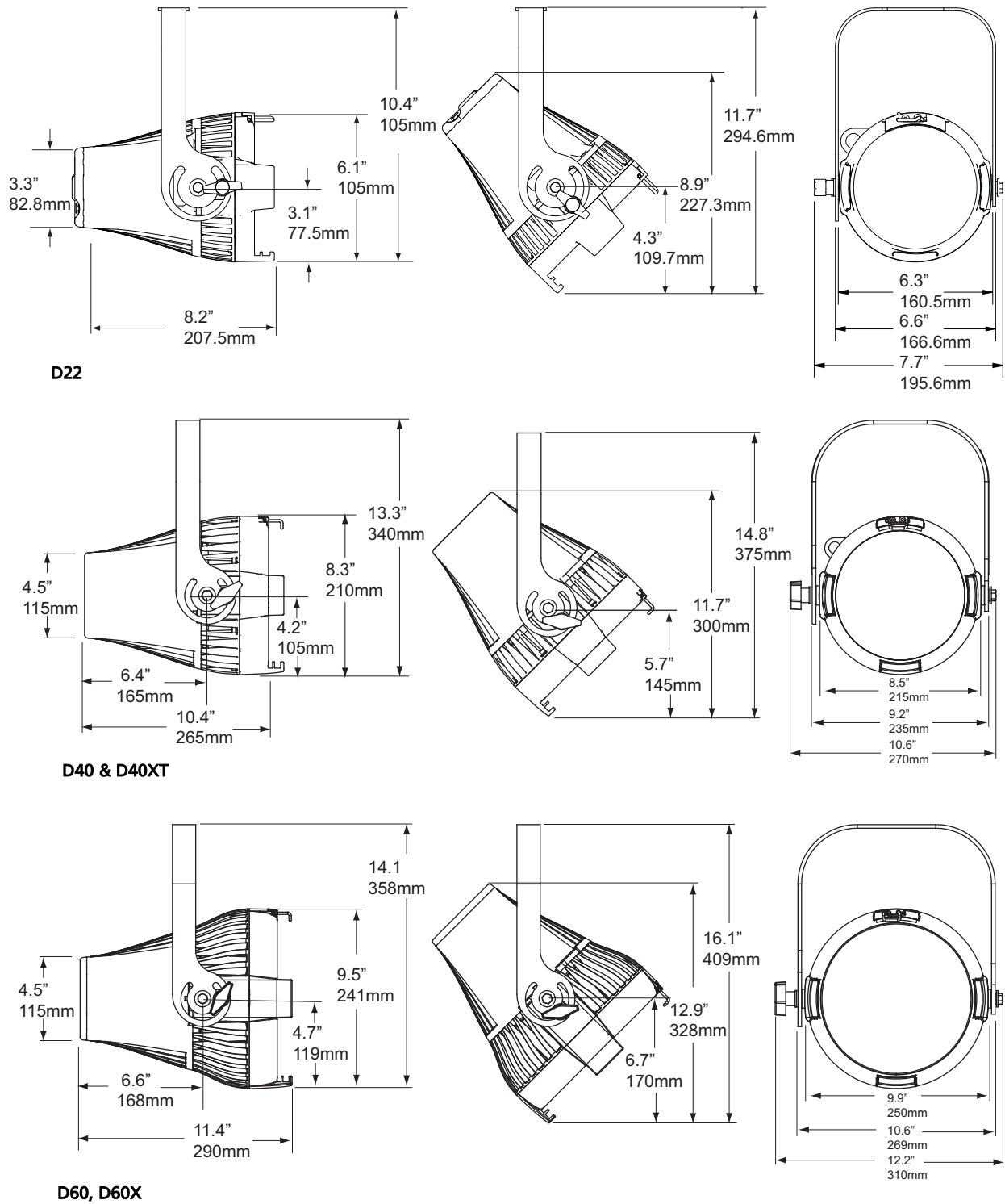

Figure-2.3 Dimensions

## Safety Cable

The safety cable (or other approved safety device) should be attached to the fixture housing and wrapped around the hanging structure (pipe). An appropriate attachment loop is provided on the protruding tab of the fixture housing. Take care to leave as little slack as possible in the safety cable to avoid the cable catching the yoke of the fixture.

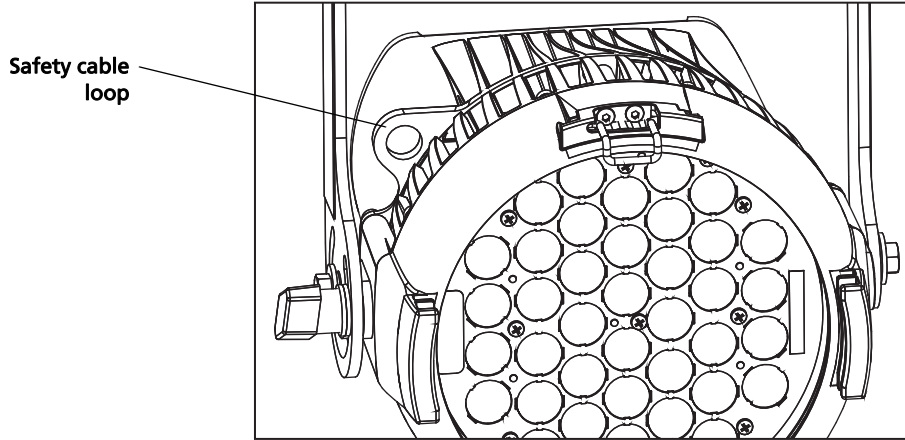

Figure-2.4 Safety Cable Loop on Fixture Housing

## Fixture Weight

Total weight depends on how the individual fixture is configured.

Model	Weight <sup>a</sup>		Shipping Weight	
	lb	kg	lb	kg
D22 Portable	6.9	3.2	8.5	3.9
D22 Canopy	6.8	3.1	8.4	3.8
D22 Track	6.4	2.9	8.0	3.6
D40	14.4	6.5	19.3	8.8
D40XT	16.5	7.5	21.4	9.7
D60	20.2	9.2	25.0	11.3
D60X	21.5	9.7	24.7	11.2

a) Does not include mounting hardware.

## Power and Data Cabling Requirements

### Power

The Desire series fixture operates on AC power, 100–240 VAC/50–60 Hz. The fixture must be connected to a non-dimmable power source in order to avoid damage to its internal power supply and other electrical components.

Mains	Europe	North America
Line	Brown	Black
Neutral	Blue	White
Ground (Earth)	Green/Yellow	Green

### Data (D40, D40XT, D60, D60X)

The Desire series fixtures operate on a DMX control signal or as stand-alone fixtures. The fixture is supplied with a 5-pin XLR DMX input connector and a 5-pin DMX Thru connector. DMX cables should be acceptable for DMX data transmission (not microphone cable) and should follow the standard pinout. The optional secondary data pair is not used by the Desire series fixtures. The maximum DMX data run from any DMX source to the last fixture in a chain is 1000 feet (300 m). Termination is required for the D40XT and D60X in the data thru port of the last fixture in each data chain. The D40 and D60 are self-terminated.

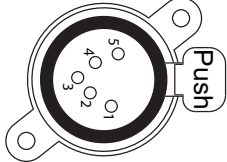
DMX512 pinout for five-pin XLR female		
	1	Common (Shield)
	2	Data -
	3	Data +
	4	not connected
	5	not connected

See [DMX Addressing](#) on [page 26](#) for additional information on DMX addressing of Desire Series fixtures.



## Data (D22)

### *Portable Model*

The Portable D22 is provided with 5-pin XLR connectors on the back for data in and thru connection to a DMX/RDM control network.

### *Canopy Mount*

The D22 Canopy Mount fixture is provided with an attached power and Cat5 data cable.

A termination board is incorporated into the mounting plate for installation onto a voltage separated junction box (provided by others) and provides termination for control wiring.

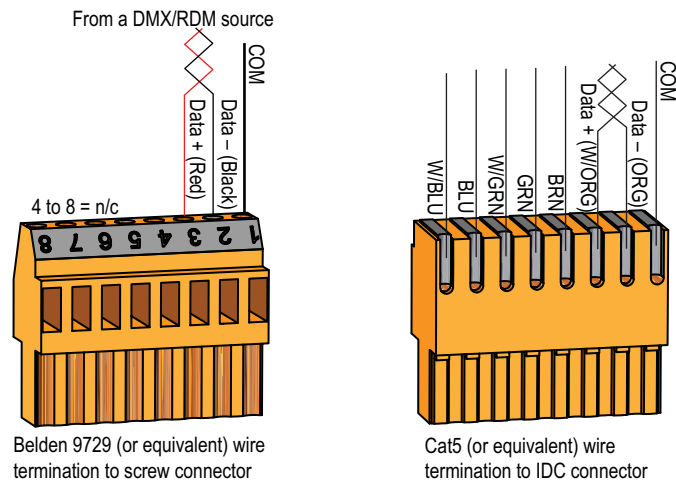

Figure-2.5 Termination Connectors

- Connection of the D22 data cable to a provided screw-down connector, which is pre-wired at the factory. The connector is plugged into the termination board. The braided shield is connected inside the fixture and should not be connected in the canopy.
- Connection of DMX/RDM input from the control source. This connection can be cable type Belden 9729 (or equivalent) to the provided screw terminal. When using Cat5 (or equivalent) cable type for DMX/RDM input, order a Cat5 termination kit from ETC (part number 4100A1013). Cat5 termination instructions and an IDC connector are provided with the termination kit.
- Connection of DMX/RDM thru to the next DMX device. This connection may also be either Belden 9729 or Cat5. Order the appropriate DMX termination kit for the cable type used from ETC (Belden 9729 use part number 4100A1012, or Cat5 use 4100A1013). Termination instructions and the appropriate connector is provided with the termination kit. Up to 32 DMX/RDM devices can be daisy-chained together per data run.

### *Track Mount*

The Track Mount fixture power and data connections are made through the track mounting adapter. No further wiring to the fixture is required. Refer to the Track installation instructions for more information. ETC manuals are available for download at [etcconnect.com](http://etcconnect.com).

## Connections

All connections and user controls are located on the back of the fixture, depending on the model. This section does not apply to the D60X fixture as there is no rear display.

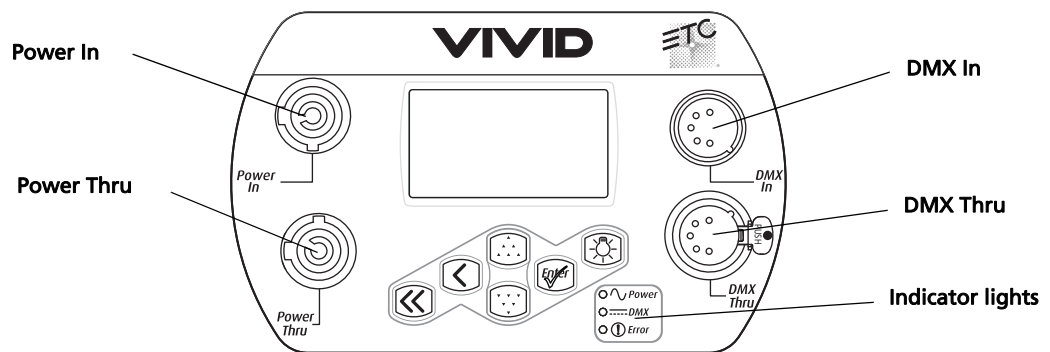

Figure-2.6 Power and DMX connections on the back of the D40 or D60 fixture

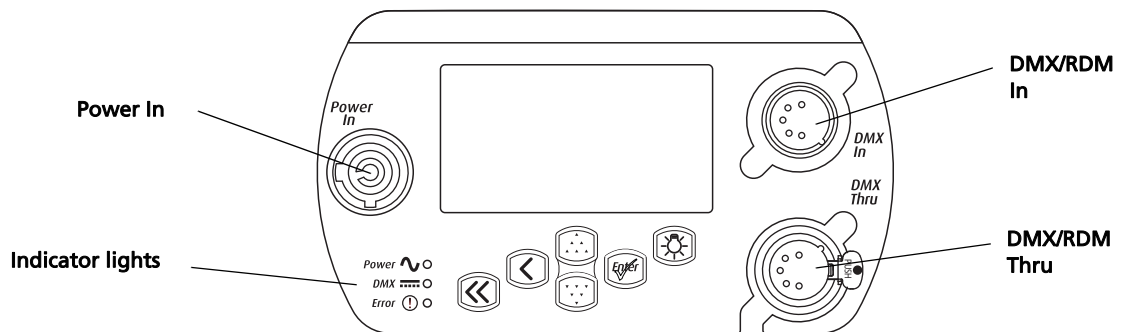

Figure-2.7 Power and DMX/RDM connections on the back of the D22 portable fixture

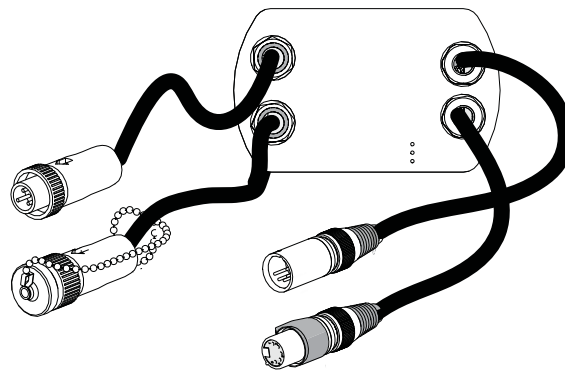

Figure-2.8 Power and DMX Connections on the back of the D60X fixture

Depending on the fixture model, connect AC input power and DMX data cables to the appropriate ports. Connect the incoming DMX data cable to the DMX Input connector. If you are daisy-chaining the data to other fixtures or DMX-controlled devices, connect the next DMX cable to the DMX Thru connector. Up to 32 fixtures can be connected together into a data daisy-chain.

For information about the user interface, refer to [User Interface Overview](#) on [page 39](#).

## D40, D60 Connections

- **Connect the AC cable:** Align and insert the power connector. Twist the connector clockwise until it locks into place.
- **Disconnect the AC cable:** Slide back the locking tab to unlock, twist the connector counterclockwise, and then pull and disconnect the power connector.
- **Connect the DMX cable:** Align and insert the DMX connector.
- **Disconnect the DMX cable:** Press the release button on the connector or on the fixture and pull the connector out.

## D40XT, D60X Connections

- **Connect the AC cable:** Align and insert the connector on the fixture's power cord to the mating connector on the extension cord or adjacent fixture. Twist the enclosure rings together to form a tight seal.
- **Disconnect the AC cable:** Loosen the enclosure rings around the connectors until fully separated, and then pull apart the two connectors.
- **Connect the DMX cable:** Align and connect the DMX connectors, pushing firmly until the locking tabs are fully activated.
- **Disconnect the DMX cable:** Press the release button on the connectors and pull the connectors apart.

## D22 Portable DMX/RDM Connections

- **Connect the DMX cable:** Align and connect the DMX connectors, pushing firmly until the locking tabs are fully activated.
- **Disconnect the DMX cable:** Press the release button on the connectors and pull the connectors apart.

## Termination

**D40XT and D60X:** The last fixture on a DMX line must be terminated with a 120-ohm resistor between pins 2 and 3.

**D22:** The last fixture on a DMX/RDM line must be terminated with a 120-ohm resistor using one of the following methods.

- **Portable:** The fixture is self-terminated, and therefore does not require other termination.
- **Canopy:** Terminate with the S1 switch on the Termination Board. Set the switch to the ON position to terminate the last fixture. All others on the DMX/RDM line must be set to OFF.
- **Track Mount:** Terminate with a DataTrack DMX Term Block (part number 7066A1030) installed at end of the track.

D40 and D60 model fixtures are self-terminating.

## Indicator Lights

The indicator lights show the status of power input (blue), DMX input (green), and fixture errors (red). When the DMX signal is lost, the green indicator flashes.

If the fixture status indicator is configured to Off, the indicator lights will not illuminate. For more information, see [Local Settings](#) on [page 69](#).

## DMX Addressing

Addresses must be set between 1 and 510.

*Each Desire fixture must be considered a separate DMX device for the purpose of DMX line-loading calculations.*

DMX line-loading practice dictates that no more than 32 devices can be daisy-chained together. Consequently, no combination of Desire fixtures totaling more than 32 DMX devices should be configured in one DMX line. For runs of fixtures totaling more than 32 DMX devices, split the DMX runs by using a DMX splitter.



**Note:** *Depending on the selected fixture profile and activated features, a fixture with a starting address higher than 499 may not have control of all parameters, even though the highest address shown on the user interface is 512.  
Addressing is not required for stand-alone operation.*

---



**Note:** *When using RDM with D22 track fixtures, ETC recommends connecting no more than 20 fixtures on a single run.*

---

## DMX Profiles

Desire D22, D40, and D40XT fixtures occupy 1 to 14 DMX channels depending on the profile and which features are turned on. Desire D60 and D60X can occupy up to 15 DMX channels depending on the profile and which features are turned on. The tables that follow describe the order and function of each channel.

### Vivid, Lustr+, Fire and Ice, and Studio HD Profiles

#### *Direct Control*

Direct Control uses one DMX channel per individual color within the LED array for a total of seven color channels, arranged according to the <SectionOnly>Color Mixes table. Each channel controls the intensity of the color from 0 to 100%. An additional, 8th DMX channel is used as a master intensity fader for controlling the brightness of the overall fixture. Channel 9 is for strobe, when enabled.

Data Channel		Control	Value	Function
1	Fixture address	Color 1 <sup>a</sup>	0 to 255	Color intensity 0 to 100%
2	Fixture address + 1	Color 2 <sup>a</sup>		
3	Fixture address + 2	Color 3 <sup>a</sup>		
4	Fixture address + 3	Color 4 <sup>a</sup>		
5	Fixture address + 4	Color 5 <sup>a</sup>		
6	Fixture address + 5	Color 6 <sup>a</sup>		
7	Fixture address + 6	Color 7 <sup>a</sup>		
8	Fixture address + 7	Intensity		Overall intensity 0 to 100%
9	Fixture address + 8	Strobe		Variable strobe control

a) See [Color Mixes](#) on [page 27](#).

#### Color Mixes

The following table shows the color mixes for each fixture type.

Color	Fire	Ice	Lustr+	Vivid	Studio HD
1	Red	Red	Red	Red	Red
2	Red-orange	—	White	Red-orange	Amber
3	Amber	—	Amber	Amber	Green-cyan
4	Green	Green	Green	Green	Blue
5	—	Cyan	Cyan	Cyan	Warm white
6	—	Blue	Blue	Blue	Cool white
7	Indigo	Indigo	Indigo	Indigo	—

## HSI (Hue Saturation Intensity) and HSIC (Hue, Saturation, Intensity, Color Temperature (White Point))

The HSI profile uses 4 channels of DMX input, corresponding to 16-bit hue (two channels: coarse and fine), saturation, and intensity. The HSI profile makes Desire fixtures compatible with conventional HSI console profiles while capitalizing on fixtures' expanded color capabilities. Channel 5 is for Strobe, when enabled. Also see [Color Matching](#) on [page 30](#).

HSIC is similar to HSI, except that it uses an additional 6th channel to control the color temperature of the white point. White point is the color temperature of the white-light output when saturation is at zero. The Red Shift function is automatically disabled in the HSIC profile. The white point address of the D60 occupies a different address. For information about the D60 DMX footprint, refer to [D60 \(Vivid, Lustr+, Fire, Ice, Studio HD\) D60X \(Vivid, Lustr+, Studio HD\)](#) on [page 33](#).

	Data Channel	Control	Value	Function
1	Fixture address	Hue coarse	0 to 65535	Hue 0 to 360°
2	Fixture address + 1	Hue fine		
3	Fixture address + 2	Saturation	0 to 255	Saturation 0 to 100%
4	Fixture address + 3	Intensity		Intensity 0 to 100%
5	Fixture address + 4	Strobe		Variable strobe control
6	Fixture address + 5	White point		Color temperature 2000–8375K



**Note:** *The HSI profile is optimized for maximum brightness at all settings.*

*At some settings, small changes in hue and saturation may produce unexpected jumps in brightness.*

*Shifts in brightness may be perceived during fades across hue, saturation, or both in cues and presets.*

## RGB

Effectively addresses all 7 colors via three channels of control. The RGB profile produces medium-quality color crossfades. It makes the Desire fixtures compatible with conventional RGB console profiles while maintaining enhanced color production from the fixture. Also see [Color Matching](#) on [page 30](#).

	Data Channel	Control	Value	Function
1	Fixture address	Red	0 to 255	Intensity 0 to 100%
2	Fixture address + 1	Green		
3	Fixture address + 2	Blue		
4	Fixture address + 3	—	—	—
5	Fixture address + 4	Strobe	0 to 255	Variable strobe control



**Note:** *The RGB profile is optimized for maximum brightness at all settings. Sometimes small changes in RGB values may produce unexpected jumps in brightness.*

*Shifts in brightness may be perceived during color crossfades in cues and presets.*

## Studio

The fixture produces only white-type light, which is adjustable from 2725 to 6450 K. The Studio profile uses 3 DMX channels to control Intensity, white point, and tint (the green/magenta balance). Tint is adjustable without affecting the white point. All three control parameters are adjustable via DMX as well as onboard with instant access via UI buttons (no menus to scroll).

Studio is the default mode for Studio HD fixtures. The Studio profile is also available on all other Desire Series fixtures. For more information, see [Studio Settings](#) on [page 72](#). Also see [Color Matching](#) on [page 30](#).

Data Channel		Control	Value	Function
1	Fixture address	Intensity	0 to 255	Intensity 0 to 100%
2	Fixture address + 1	White point: 2725 to 6450 K		0 to 1 = 3200 K 2 to 253 = Adjustment from 2725 to 6450 K 254 to 255 = 5600 K
3	Fixture address + 2	Tint		0 to 1 = neutral white 2 to 127 = full plus-green to neutral white 128 = neutral white 129 to 255 = neutral white to full minus-green (full magenta)
4	Fixture address + 3	—	—	—
5	Fixture address + 4	Strobe	0 to 255	Variable strobe control

## Strobe

In most profiles (Vivid, Lustr+, Fire and Ice, Studio HD), strobe is assigned to channel 5. It adds another channel to any of the DMX profiles. Under the Advanced Settings menu, the strobe function may be disabled and the additional channel for strobe will not be used by the fixture. With strobe at either DMX value 0 or 255, the fixture output is constantly on. At DMX 1, the fixture strobes slowly and increases in speed toward DMX 254.

## Plus Seven

Plus Seven adds precision color-control channels to the HSI, HSIC, RGB, and Studio profiles. For example, HSI with Plus Seven enabled becomes a 14-channel profile. Placing channel 7 at a value over 51% activates the 14-channel profile within the fixture. The desired color and intensity is achieved by using the HSI or RGB channels as a starting point. Channels 8 to 14 represent the native LED colors of the fixture and allow you to adjust each color up or down in order to fine-tune the overall color output.

The D60 Plus Seven addresses occupy different addresses. For information about the D60 DMX footprint, refer to [D60 \(Vivid, Lustr+, Fire, Ice, Studio HD\) D60X \(Vivid, Lustr+, Studio HD\)](#) on [page 33](#).



**Note:** *When Plus Seven is enabled and the individual control channels have been adjusted, those adjustments continue to apply after choosing a new color mix. For best results, reset each of the individual control channels to 128 (50%) before choosing a new initial color mix.*



**Note:** *Depending on the initial color mix, some LED colors may begin at full intensity. Moving the individual control channels for these colors from 128 to 255 (50–100%) will produce no effective change from the initial color mix. Conversely, some LED colors may begin at zero intensity, and moving individual control channels from 128 to 0 (50–0%) will produce no change.*

Data Channel		Control	Value	Function
7	Fixture address + 6	Plus Seven control	0 to 129 = Plus Seven disabled 130 to 255 = Plus Seven enabled	Disable or enable Plus Seven control
8	Fixture address + 7	Color 1 <sup>a</sup>	128 = No change from initial color mix 129 to 255 = Increase from starting value to full intensity 127 to 0 = Decrease from starting value to zero intensity	Alter the individual LED colors within the array to a maximum of full intensity or a minimum of zero intensity.
9	Fixture address + 8	Color 2 <sup>a</sup>		
10	Fixture address + 9	Color 3 <sup>a</sup>		
11	Fixture address + 10	Color 4 <sup>a</sup>		
12	Fixture address + 11	Color 5 <sup>a</sup>		
13	Fixture address + 12	Color 6 <sup>a</sup>		
14	Fixture address + 13	Color 7 <sup>a</sup>		

a) See [Color Mixes](#) on [page 27](#).

## Color Matching

The color output of all Desire fixtures is calibrated at the factory. When operating in the RGB, HSI, HSIC, or Studio profile, each fixture makes accommodations for the specific LEDs in its array and produces output that is consistent with other fixtures, whether or not they utilize LEDs from the same production batch. Operating with Plus Seven settings adjustments bypasses this calibration, and multiple fixtures may produce slightly different outputs when controlled as a group.



## Studio Daylight and Studio Tungsten Profiles

### *Direct Control*

The first DMX channel always controls Intensity from 0 to 100%.

	Data Channel	Control	Value	Function
1	Fixture address	Intensity	0 to 255	Intensity 0 to 100%
2	Fixture address + 1	Strobe	0 to 255	Variable strobe control

### Fan Control (D60)

Only the D60 fixtures have a fan. Thus, options for Fan Control are available only on D60 fixtures. The Fan setting allows four options: DMX, Slow, Fast, and Automatic.



**Note:** *The D60X does not have a fan, but a fan channel does appear in its profile.*

With Fan set to DMX, an additional channel of DMX control is added to the fixture profile, immediately following the channel for Strobe. Control is as follows:

- **DMX 0:** Fan turns on and off automatically, as needed for cooling. Fan remains off when not required by the fixture.
- **DMX 1 to 254:** Fan is forced on at a continuously variable speed from low to high. Occasionally, the fan speed may be increased automatically by the fixture for additional cooling power when required.
- **DMX 255:** Fan is forced on at its highest, loudest speed for maximum consistency of noise produced by the fixture.

With Fan set to Slow, Fast, or Automatic, there is no channel for fan control within the DMX profile. At Slow and Fast settings, the fan operates whenever the fixture is powered on, independent of other fixture settings or control.

- **Slow:** Fan runs continuously at a low-noise speed. When necessary, the fan speed may be increased automatically by the fixture for additional cooling power.
- **Fast:** Fan runs continuously at its highest, loudest speed, which never increases automatically.
- **Automatic:** Fan operation is intermittent and based entirely on the fixture's internally calculated cooling requirements.

## DMX Footprints and Channel Mapping

### D22, D40, D40XT, D60 and D60X (Studio Tungsten and Daylight)

Channel	Control
1	Intensity
2	Strobe*
3	Fan control*

\* When this feature is enabled.

### D22 (Lustr+ and Studio HD)

Channel	HSI	HSIC	RGB	Studio	Direct
1	Hue	Hue	Red	Intensity	Color 1
2	Hue fine	Hue fine	Green	Color temp	Color 2
3	Saturation	Saturation	Blue	Tint	Color 3
4	Intensity	Intensity	N/A	N/A	Color 4
5	Strobe*	Strobe*	Strobe*	Strobe*	Color 5
6	N/A	Color temp	N/A	N/A	Color 6
7	Plus7 on/off*	Plus7 on/off*	Plus7 on/off*	Plus7 on/off*	Color 7
8	Plus7 - (1)*	Plus7 - (1)*	Plus7 - (1)*	Plus7 - (1)*	Intensity
9	Plus7 - (2)*	Plus7 - (2)*	Plus7 - (2)*	Plus7 - (2)*	Strobe <sup>a</sup>
10	Plus7 - (3)*	Plus7 - (3)*	Plus7 - (3)*	Plus7 - (3)*	N/A
11	Plus7 - (4)*	Plus7 - (4)*	Plus7 - (4)*	Plus7 - (4)*	N/A
12	Plus7 - (5)*	Plus7 - (5)*	Plus7 - (5)*	Plus7 - (5)*	N/A
13	Plus7 - (6)*	Plus7 - (6)*	Plus7 - (6)*	Plus7 - (6)*	N/A
14	Plus7 - (7)*	Plus7 - (7)*	Plus7 - (7)*	Plus7 - (7)*	N/A

\* When this feature is enabled.

## D40 (Vivid, Lustr+, Fire, Ice, Studio HD)

Channel	HSI	HSIC	RGB	Studio	Direct
1	Hue	Hue	Red	Intensity	Color 1
2	Hue fine	Hue fine	Green	Color temp	Color 2
3	Saturation	Saturation	Blue	Tint	Color 3
4	Intensity	Intensity	N/A	N/A	Color 4
5	Strobe*	Strobe*	Strobe*	Strobe*	Color 5
6	N/A	Color temp	N/A	N/A	Color 6
7	Plus7 on/off*	Plus7 on/off*	Plus7 on/off*	Plus7 on/off*	Color 7
8	Plus7 - (1)*	Plus7 - (1)*	Plus7 - (1)*	Plus7 - (1)*	Intensity
9	Plus7 - (2)*	Plus7 - (2)*	Plus7 - (2)*	Plus7 - (2)*	Strobe <sup>a</sup>
10	Plus7 - (3)*	Plus7 - (3)*	Plus7 - (3)*	Plus7 - (3)*	N/A
11	Plus7 - (4)*	Plus7 - (4)*	Plus7 - (4)*	Plus7 - (4)*	N/A
12	Plus7 - (5)*	Plus7 - (5)*	Plus7 - (5)*	Plus7 - (5)*	N/A
13	Plus7 - (6)*	Plus7 - (6)*	Plus7 - (6)*	Plus7 - (6)*	N/A
14	Plus7 - (7)*	Plus7 - (7)*	Plus7 - (7)*	Plus7 - (7)*	N/A

\* When this feature is enabled.

## D60 (Vivid, Lustr+, Fire, Ice, Studio HD)

### D60X (Vivid, Lustr+, Studio HD)

Channel	HSI	HSIC	RGB	Studio	Direct
1	Hue	Hue	Red	Intensity	Color 1
2	Hue fine	Hue fine	Green	Color temp	Color 2
3	Saturation	Saturation	Blue	Tint	Color 3
4	Intensity	Intensity	N/A	N/A	Color 4
5	Strobe*	Strobe*	Strobe*	Strobe*	Color 5
6	Fan control*	Fan control*	Fan control*	Fan control*	Color 6
7	N/A	Color temp	N/A	N/A	Color 7
8	Plus7 on/off*	Plus7 on/off*	Plus7 on/off*	Plus7 on/off*	Intensity
9	Plus7 - (1)*	Plus7 - (1)*	Plus7 - (1)*	Plus7 - (1)*	Strobe*
10	Plus7 - (2)*	Plus7 - (2)*	Plus7 - (2)*	Plus7 - (2)*	Fan control*
11	Plus7 - (3)*	Plus7 - (3)*	Plus7 - (3)*	Plus7 - (3)*	N/A
12	Plus7 - (4)*	Plus7 - (4)*	Plus7 - (4)*	Plus7 - (4)*	N/A
13	Plus7 - (5)*	Plus7 - (5)*	Plus7 - (5)*	Plus7 - (5)*	N/A
14	Plus7 - (6)*	Plus7 - (6)*	Plus7 - (6)*	Plus7 - (6)*	N/A
15	Plus7 - (7)*	Plus7 - (7)*	Plus7 - (7)*	Plus7 - (7)*	N/A

\* When this feature is enabled.

## Quick Color (Vivid, Lustr+, Fire and Ice, Studio HD)

Quick Color allows you to easily select a color and its intensity from a predefined menu. This feature overrides any presets or sequences previously selected and is only available when there is no external DMX signal to the fixture. For a list of available colors, see the table on [page 56](#). For additional information on Quick Color setup, see [Quick Color \(Vivid, Lustr+, Fire and Ice, Studio HD\)](#) on [page 64](#).

## DMX Profile Tables

### *D40/D40XT (Vivid, Lustr+, Fire, Ice, Studio HD) and D22 (Lustr+, Studio HD)*

DMX Profile	DMX Channels	Channel Assignments		Notes
		Vivid, Lustr+	Studio HD	
Direct	9	1 - Red	1 - Red	Direct control of each individual color with a separate master intensity channel. The nine-channel profile will produce the highest quality color crossfades.
		2 - Orange (White if Lustr+)	2 - Orange	
		3 - Amber	3 - Amber	
		4 - Green	4 - Green	
		5 - Cyan	5 - 3200 K White	
		6 - Blue	6 - 5000 K White	
		7 - Indigo	7 - Indigo	
		8 - Intensity	8 - Intensity	
		9 - Strobe	9 - Strobe	
RGB	5 (Ch. 4 not used)	1 - Red		Effectively addresses all seven colors via three channels of control. RGB profile will produce medium quality color crossfades.
		2 - Green		
		3 - Blue		
		4 - n/a		
		5 - Strobe		
HSI	5	1 - Hue (coarse)		High resolution hue (two channels), saturation, and intensity control. HSI mode will produce color crossfades around the color space.
		2 - Hue (fine)		
		3 - Saturation		
		4 - Intensity		
		5 - Strobe		
HSIC	6	1 - Hue (coarse)		High-resolution hue, saturation, and intensity control as above, with the addition of a color point channel to adjust the color temperature of the fixture in both white light and color. Color crossfade performance is the same as HSI.
		2 - Hue (fine)		
		3 - Saturation		
		4 - Intensity		
		5 - Strobe		
		6 - Color Point (CCT)		
Studio	3	1 - Intensity		Controls fixture as a white light unit. If no DMX (i.e., console input) is present, a fixture can be adjusted for these three parameters on the user interface at the back of the unit.
		2 - Color Point (CCT)		
		3 - Tint		

DMX Profile	Channel Assignments		Notes
	Vivid, Lustr+	Studio HD	
Plus Seven	1 - Hue (coarse) 2 - Hue (fine) 3 - Saturation 4 - Intensity 5 - Strobe 6 - n/a 7 - Plus Seven Control on/off 8 - Red 9 - Orange (white if Lustr+) 10 - Amber 11 - Green 12 - Cyan 13 - Blue 14 - Indigo		<p>Adds seven additional color control channels to RGB, HSI, HSIC, and Studio input profile settings. For example, HSI with 'Plus Seven' enabled becomes a 15-channel profile.</p> <p>The desired color and intensity are achieved by using the HSI or RGB channels.</p> <p>Placing channel seven at a value over 51% gives the fixture a 14-channel profile.</p> <p>Channels 8–14 represent the native colors of the fixture and allow the operator to adjust individual color channels to fine-tune the color output.</p>
Strobe	Variable strobe control: 0% is no strobe. The fixture output will strobe more rapidly as the strobe-channel value approaches 100%.		

***D60 (Vivid, Lustr+, Fire, Ice, Studio HD) and D60X (Vivid, Lustr+ and Studio HD)***

DMX Profile	DMX Channels	Channel Assignments		Notes
		Vivid, Lustr+	Studio HD	
Direct	9	1 - Red	1 - Red	Direct control of each individual color with a separate master intensity channel. The nine-channel profile will produce the highest quality color crossfades.
		2 - Orange (White if Lustr+)	2 - Orange	
		3 - Amber	3 - Amber	
		4 - Green	4 - Green	
		5 - Cyan	5 - 3200 K White	
		6 - Blue	6 - 5000 K White	
		7 - Indigo	7 - Indigo	
		8 - Intensity	8 - Intensity	
		9 - Strobe	9 - Strobe	
RGB	5 (Ch. 4 not used)	1 - Red		Effectively addresses all seven colors via three channels of control. RGB profile will produce medium quality color crossfades.
		2 - Green		
		3 - Blue		
		4 - n/a		
		5 - Strobe		
HSI	5	1 - Hue (coarse)		High resolution hue (two channels), saturation, and intensity control. HSI mode will produce color crossfades around the color space.
		2 - Hue (fine)		
		3 - Saturation		
		4 - Intensity		
		5 - Strobe		
HSIC	6	1 - Hue (coarse)		High-resolution hue, saturation, and intensity control as above, with the addition of a color point channel to adjust the color temperature of the fixture in both white light and color. Color crossfade performance is the same as HSI.
		2 - Hue (fine)		
		3 - Saturation		
		4 - Intensity		
		5 - Strobe		
		6 - Color Point (CCT)		
Studio	3	1 - Intensity		Controls fixture as a white light unit. If no DMX (i.e., console input) is present, a fixture can be adjusted for these three parameters on the user interface at the back of the unit.
		2 - Color Point (CCT)		
		3 - Tint		

DMX Profile	DMX Channels	Channel Assignments		Notes
		Vivid, Lustr+	Studio HD	
Plus Seven	7 additional channels	1 - Hue (coarse)		Adds seven additional color control channels to RGB, HSI, HSIC, and Studio input profile settings. For example, HSI with 'Plus Seven' enabled becomes a 15-channel profile.
		2 - Hue (fine)		
		3 - Saturation		
		4 - Intensity		
		5 - Strobe		
		6 - n/a		
		7 - Plus Seven Control on/off		The desired color and intensity are achieved by using the HSI or RGB channels.
		8 - Red		
		9 - Orange (white if Lustr+)		Placing channel seven at a value over 51% gives the fixture a 14-channel profile.
		10 - Amber		
		11 - Green		
		12 - Cyan		Channels 8–14 represent the native colors of the fixture and allow the operator to adjust individual color channels to fine-tune the color output.
		13 - Blue		
		14 - Indigo		
Strobe	1 additional channel			Variable strobe control: 0% is no strobe. The fixture output will strobe more rapidly as the strobe-channel value approaches 100%.

***D40XT, D40, D60 and D60X (Studio Tungsten and Studio Daylight) and D22 (Studio Tungsten and Studio Daylight)***

DMX Profile	DMX Channels	Channel Assignments	Notes
Studio	3	1 - Intensity	Direct control of each individual color with a separate master intensity channel. The ten-channel profile will produce the highest quality color crossfades.
		2 - Strobe	
		3 - Fan Control (D60 only)	
Direct	3	1 - Intensity	
		2 - Strobe	
		3 - Fan Control (D60 and D60X)	

## Install Accessories

The accessory holder is equipped with a spring-loaded retaining clip that prevents secondary lenses and accessories from falling out.

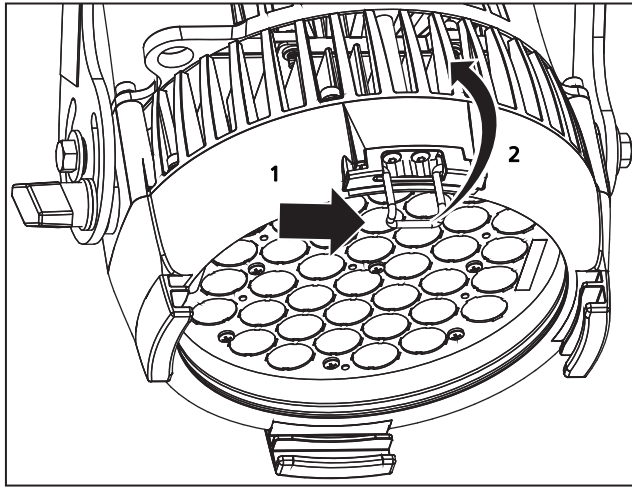

Figure-2.9 Retaining Clip in the Locked Position



**WARNING:** Make sure all accessories are locked into position with the retaining clip before hanging the fixture.

- 1: Release the retaining clip by pushing it sideways while gently pushing it towards the back of the fixture.
- 2: Insert the accessory or secondary lens in either of the two slots.
- 3: Lock the retaining clip by pushing forward and sliding left as viewing the fixture shown in <Blue>Figure-2.9.



**Note:** For D40 and D40XT, use only secondary lenses or accessories with a 7.5 inch mounting flange.

To order glass lenses from ETC, contact your local dealer.

- D40 glass lens: ETC part number 7410A4001
- D60 glass lens: ETC part number 7410A4003



# Chapter 3

## Basic Menu Navigation

---

### User Interface Overview

The Desire Series user interface (UI) consists of an LCD and keypad. All of the basic information is displayed on the LCD and the keypad is used to navigate through the menus. Use the LCD and keypad to program the fixture for your specific application.



**Note:** *This section does not apply to D60X fixtures because the D60X does not have a user interface.*

---

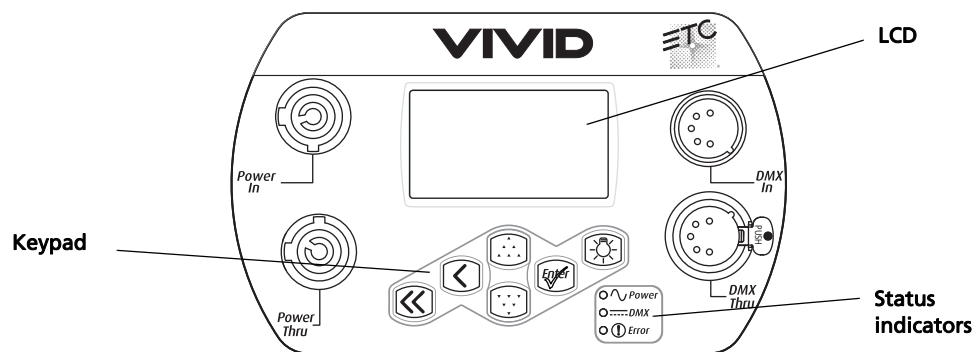

Figure-3.1 User Interface on Back of D40 or D60 Fixture

### LCD

The Desire features a backlit LCD capable of displaying 8 rows of text with 21 characters per line. The first row is reserved for the menu title.

To adjust the contrast of the LCD, press and hold [ < ] and then press [ ▲▲▲ ] or [ ▼▼▼ ].

## Keypad

Use the keypad buttons to access and navigate the menus on the LCD.

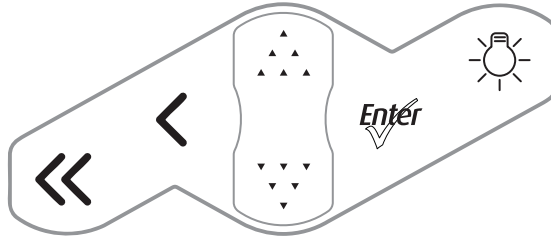











Figure-3.2 Keypad Buttons

-  **Home**  
Opens the home screen.
-  **Back**  
Cancels the current operation and returns to the previous screen. Multiple presses of the back button will eventually take you to the status display.
-  **Up**  
Increases a value or menu choice by one. Pressing and holding the button increases the rate of change.
-  **Down**  
Decreases a value or menu choice by one. Pressing and holding the button increases the rate of change.
-  **Light Bulb**  
Opens the Presets and Sequences menu.
-  **Enter**
- Activates a menu selection or stores a value. For most settings, press [Enter] repeatedly to scroll through available options while the setting is highlighted, and then press [] or [] to commit the change and move to a different setting.
  - Certain settings require the selection of a numeric value. Press [Enter] once to highlight the number, press [] or [] to reach the desired value, and then press [Enter] to commit the change.



**Note:** When the fixture is in the stand-alone mode of the Studio profile, the functionality of the buttons changes. For more information, see [Operation From Home Status Screen \(Studio Stand-alone\)](#) on page 73.

## Keypad Lockout

The keypad may be locked to prevent unauthorized access to fixture settings. Press  $\left[ \begin{smallmatrix} \blacktriangle \\ \blacktriangle \\ \blacktriangle \end{smallmatrix} \right]$  and  $\left[ \begin{smallmatrix} \blacktriangledown \\ \blacktriangledown \\ \blacktriangledown \end{smallmatrix} \right]$  simultaneously for approximately 3 seconds. A small padlock icon appears in the corner of the LCD screen to indicate that the keypad is locked. To unlock, again press  $\left[ \begin{smallmatrix} \blacktriangle \\ \blacktriangle \\ \blacktriangle \end{smallmatrix} \right]$  and  $\left[ \begin{smallmatrix} \blacktriangledown \\ \blacktriangledown \\ \blacktriangledown \end{smallmatrix} \right]$  simultaneously for approximately 3 seconds. The padlock icon disappears. The locked or unlocked status of the keypad persists through on/off power cycles. Keypad lockout does not affect access to fixture settings via RDM.

## Status Indicators

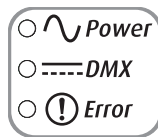

Figure-3.3 Status Indicators on the Back of the Fixture

The status indicators are three small, colored LEDs on the user interface that indicate the status of:

- **Power:** Illuminates blue when AC power is supplied to the fixture.
- **DMX:** Illuminates green when an active DMX signal is being received by the fixture.
- **Error:** Illuminates red only when the fixture is experiencing a data error, high internal temperature, or other abnormal condition.

Status indicators are on by default. You can turn them off through the Local Settings menu. For more information, see [Local Settings](#) on [page 69](#).

## Screen Navigation

When the Desire fixture is powered up, a splash screen briefly displays, followed by a status screen.

The menu system and LCD backlight are set by default to “sleep” after one minute of inactivity. Any button press wakes the LCD backlight. You can set the inactivity time on the Local Settings menu. To “wake up” the display and go to the button’s respective function, press any keypad button. For example, if you press  $\left[ \begin{smallmatrix} \blacktriangledown \\ \blacktriangledown \\ \blacktriangledown \end{smallmatrix} \right]$ , the LCD backlight comes on and the Main Menu displays. For more information, see [Local Settings](#) on [page 69](#).

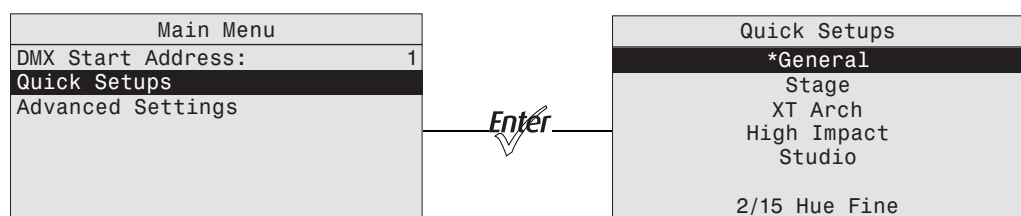

Figure-3.4 Main Menu with Quick Setups Selected and the Result of Pressing Enter.  
Vivid, Lustr+, Fire and Ice, Studio HD screen shown.

Press  $\left[ \begin{smallmatrix} \blacktriangle \\ \blacktriangle \\ \blacktriangle \end{smallmatrix} \right]$  or  $\left[ \begin{smallmatrix} \blacktriangledown \\ \blacktriangledown \\ \blacktriangledown \end{smallmatrix} \right]$  to highlight a menu item. Press  $\left[ \begin{smallmatrix} \blacktriangledown \\ \blacktriangledown \\ \blacktriangledown \end{smallmatrix} \right]$  to select the item. The asterisk (\*) indicates that the item is currently active.

## Status (Home) Screens

The status (home) screens display when you press [ <<< ] or when there is no activity for a specific time. The home screens display the status of multiple fixture settings. These may or may not include:

- Quick Setup
- Input settings
- DMX address
- LED settings
- Preset or Sequence that may be active
- Master or Slave status, when applicable
- Diagnostic messages
- DMX signal status
- Software version

Most of the settings can be adjusted either on the home screen or within a short series of menus. When a quick setup is selected, the settings of the setup are displayed on the home screen.

For more information about status screens, see [Home Screen Displays](#) on [page 44](#).

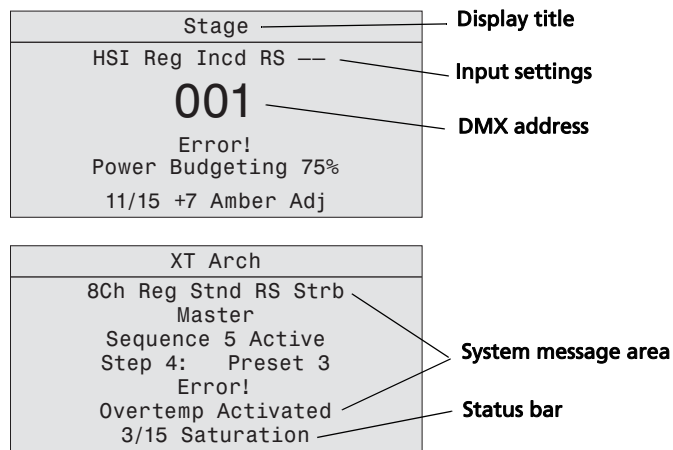

Figure-3.5 Examples of Status Screens

### ***Display Title***

A menu's title appears in the first row of every display for easy navigation.

### ***Input Settings***

Displays the parameters for the Quick Setup that is active. For more information, see [Home Screen Displays](#) on [page 44](#).

### ***DMX Address***

Indicates the DMX address when the fixture is receiving DMX. For more information, see [DMX Start Address](#) on [page 45](#).

## ***System Message Area***

Displays status messages, which vary depending on the function that is currently active.

### **Master or Slave**

Indicates if the fixture is the master or slave when the a string of fixtures is running together in stand-alone operation. For more information, see [Master/Slave Operation](#) on [page 65](#).

### **Sequence**

Indicates whether or not a sequence is active and if so, which sequence is active. For more information, see [Presets & Sequences](#) on [page 55](#).

### **Step**

Indicates whether or not a preset is active and if so, which step and preset is active. For more information, see [Presets & Sequences](#) on [page 55](#).

### **Preset**

Indicates which preset is currently active. For more information, see [Presets & Sequences](#) on [page 55](#).

### **Error**

Displays error messages. See [Error Messages](#) on [page 79](#) for a complete listing of possible errors and the actions required to clear them.

## ***Status Bar***

Indicates the DMX channels, type, and effect the setup uses.

## **Menu Navigation**

The Desire menu is designed with consistent navigation from the user interface (UI) using the keypad.

The Main Menu is the root for all menu navigation. When an item is selected from the Main Menu, a secondary menu displays, which includes multiple functions for selection. Some secondary menus lead to additional menus. Select a menu item to edit its settings or to proceed to a deeper menu. Items that may be edited are indicated with descriptive text followed by a colon (:) and a value.

The keypad is used to edit specific objects on the operation menu, such as DMX address, Preset and Sequence numbers, fade and delay times, etc. Once an edit has been made, press [**Enter**] to accept the selection.

Use [**Enter**] to navigate to the next object for action or edit. To return to the previous operation, press [ < ]. Continue pressing [ < ] to return to the menu list and then the Main Menu.

You can also use [ < ] with any Yes or No dialog box. Pressing [ < ] is the same as selecting No.

# Chapter 4

## Operation

### Home Screen Displays



**Note:** *This section does not apply to the D60X fixture because there is no user interface screen. See [Configure D60X using RDM on page 76](#) for programming information.*

Depending on the fixture settings, the following are displayed in the system message area on the respective home (status) screens.

#### Vivid, Lustr+, Fire and Ice, Studio HD

Parameter	Stage	High Impact	Studio	General
Profile	HSI	RGB	Studio	Direct Control (Dir)
Output Setting	Regulated (Reg)	Boost (Bst)	Regulated (Reg)	Regulated (Reg)
Dimming Curve	Incandescent (Incd)	Quick (Qik)	Linear (Lin)	Standard (Std)
Red Shift (RS)	Disabled	Disabled	Disabled	Disabled
Strobe (Str)	On	On	On	On

#### Studio Daylight and Studio Tungsten

Parameter	Studio	Stage	Single Channel
Profile	Direct	Direct	Direct
Output Setting	Regulated (Reg)	Regulated (Reg)	Regulated (Reg)
Dimming Curve	Linear (Lin)	Incandescent (Incd)	Standard (Std)
Strobe (Str)	On	On	Off
Fan Control (D60 only)	DMX	DMX	Automatic (Auto)

#### ***Profile (Vivid, Lustr+, Fire and Ice, Studio HD)***

The control profile defines the number and control parameter assignments of input channels for intensity and color-control. For more information, see [DMX Profiles on page 27](#).

#### ***Profile (Studio Daylight and Studio Tungsten)***

The control profile for Studio Daylight and Studio Tungsten includes only the Direct option. The first channel of DMX control adjusts fixture Intensity from 0 to 100%. For more information, see [Studio Daylight and Studio Tungsten Profiles on page 31](#).

#### ***Output Setting***

Output is the way and amount to which the fixture constrains the overall power going to the LED array, which determines how consistent the fixture's brightness may be. For more information, see [Output on page 51](#).

#### ***Dimming Curve***

Dimming curve is the way that the fixture responds to changes in the control signal for overall intensity. For more information, see [Curve on page 52](#).

## Red Shift

Red shift replicates the warming of an incandescent filament's color temperature change as it dims. For more information, see [Red Shift](#) on [page 54](#).

## Strobe

Strobe flashes the output of the LED array. For more information, see [Strobe](#) on [page 48](#).

## Fan Control (D60)

The fan on D60 fixtures can be forced on via DMX control or by adjusting settings under the Advanced Settings menu. For more information, see [Fan Control \(D60\)](#) on [page 31](#).

## Thermal Shutdown Warning

Displayed as OverTemp, it is what the fixture does to visibly warn you that it has become overheated and has gone into a shutdown status, which is maintained until the fixture returns to a safe operating temperature. For more information, see [OverTemp](#) on [page 71](#).

## Data Loss Behavior

What happens to the fixture's output when the external control signal is lost. For more information, see [Data Loss](#) on [page 49](#).

## Status Indicators

Status Indicators are on by default. For more information, see [Status Indicators](#) on [page 70](#).

## Main Menu

The Main Menu can be accessed at any time while viewing other screens by pressing [ << ], then [ *Enter* ].

## DMX Start Address

Use the DMX Start Address to set the DMX address of the fixture. Also see [DMX Settings](#) on [page 47](#).



Figure-4.1 Selecting DMX Start Address on the Main Menu

- 1: On the **Main Menu**, scroll to **DMX Start Address**.
- 2: Press [ *Enter* ] to select the address number.
- 3: Use [ ] or [ ] to scroll to the desired **address**.
- 4: Press [ *Enter* ].
- 5: Press [ << ] to return to the home screen.

## Quick Setups

Quick Setups are groupings of predefined fixture performance settings based on typical applications.

Use the Quick Setups menu to select the desired setup. When a setup is active, the status bar at the bottom of the screen indicates the DMX channels, their functions, and arrangements that the setup uses. For descriptions of the different Quick Setups, see [Quick Setups Menu](#) on [page 8](#).

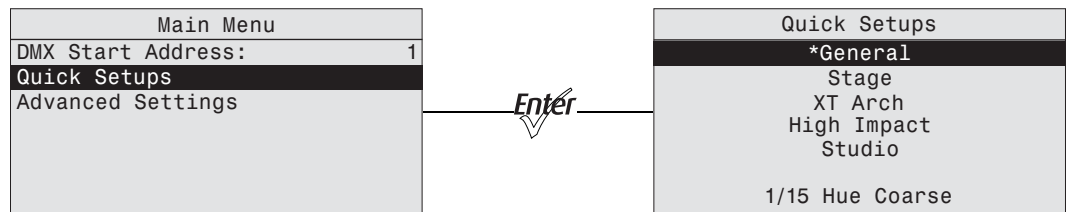

Figure-4.2 Selecting Quick Setup on the Main Menu

- 1: On the **Main Menu**, scroll to **Quick Setups**.
- 2: Press **[Enter]**.
- 3: Scroll to the desired profile and then press **[Enter]**.  
An asterisk (\*) next to the profile name indicates that profile is active.
- 4: Press **[<<]** to return to the home screen.  
The top line of the home screen displays the name of the active profile.

## Advanced Settings

The Advanced Settings menu is for experienced users or for applications that entail very carefully defined performance parameters. You can make individual adjustments of all fixture settings for customized control.



Figure-4.3 Advanced Menu From from the Main Menu

When opening Advanced Settings, all fixture settings remain at their most recent values until readjusted. The fixture automatically goes into Advanced Settings when any settings are altered from one of the preset Quick Setups.

## Advanced Menu

The Advanced Menu provides access to various fixture settings and specific operations. The Advanced Menu is accessed from the **Main Menu** by pressing **[▲▲▲]** or **[▼▼▼]** to select **Advanced Settings** and then pressing **[Enter]**.



## DMX Settings

The current DMX settings are shown in the DMX Settings screen. Use the DMX Settings screen to customize the following:

- DMX start address
- DMX profile
- Strobe
- Data loss
- Plus Seven (Vivid, Lustr+, Fire and Ice, Studio HD)

The two lower lines of the DMX Settings screen display the number of DMX channels used by the fixture, according to the options selected, and their arrangement, in order.

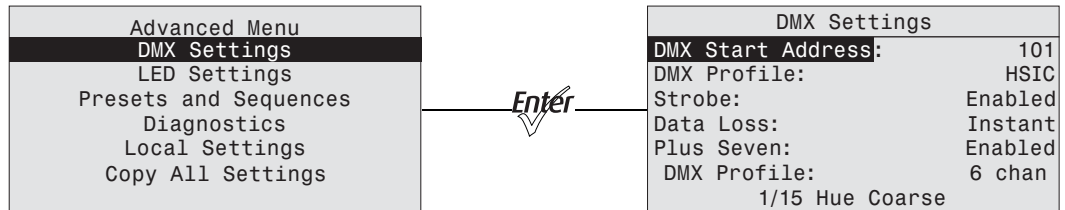

Figure-4.4 Selecting DMX Settings From the Advanced Menu

### ***DMX Start Address***

The DMX start address is selectable from 1 to 512.

- 1: On the **Advanced Menu**, scroll to **DMX Settings**.
- 2: Press [**Enter**].
- 3: With **DMX Start Address** selected, press [**Enter**] to select the value.
- 4: Then press [**▲▲▲**] or [**▼▼▼**] to set the desired address.
- 5: Press [**Enter**].



**Note:** *A change to the DMX start address on this screen will override and update the DMX start address selected on the Home screen.*

## DMX Profile

The current DMX profile is displayed on the DMX Settings menu. You can customize the setting by selecting a different profile. For detailed information about each profile, see [DMX Profiles](#) on [page 27](#).

- 1: On the **DMX Settings** menu, scroll to **DMX Profile**.

DMX Settings	
DMX Start Address:	101
<b>DMX Profile:</b>	HSIC
Strobe:	Enabled
Data Loss:	Instant
Plus Seven:	Enabled
DMX Profile:	6 chan
	3/15 Saturation

Figure-4.5 Selecting DMX Profile on the DMX Settings Menu

- 2: Press [**Enter**] to set the desired profile.

## Strobe

Strobe adds another DMX channel of control at channel 5 (or channel 9 when operating in a Direct Control profile). When enabled, the Strobe channel controls the fixture output as follows.

DMX Value	Strobe Effect
0	Full on
1 to 254	Variable rate from slow to fast
255	Full on

- 1: On the **DMX Settings** menu, scroll to **Strobe**.

DMX Settings	
DMX Start Address:	101
DMX Profile:	HSIC
<b>Strobe:</b>	On
Data Loss:	Instant
Plus Seven:	On
DMX Profile:	6 chan
	5/15 Strobe

Figure-4.6 Enabling Strobe on the DMX Settings Menu

- 2: Press [**Enter**] to toggle between **On** and **Off**.
- 3: Press [**▲▲▲**] or [**▼▼▼**] to commit the option.

## Fan Control (D60 only)

Fan Control adds another DMX channel of control when set to DMX. Alternate settings are Slow, Fast, and Automatic. For more information, see [Fan Control \(D60\)](#) on [page 31](#).

- 1: On the DMX Settings menu, scroll to **Fan**.

DMX Settings	
DMX Start Address:	101
DMX Profile:	Direct
Strobe Mode:	On
Data Loss:	Instant
<b>Fan Mode:</b>	Auto
6/15 Fan	

Figure-4.7 Setting the Fan Mode on the DMX Settings Menu

- 2: Press [**Enter**] to scroll through the available options.
- 3: Press [**▲▲▲**] or [**▼▼▼**] to commit the option.

## Data Loss

Data Loss is what happens to the fixture's output when the external control signal (either DMX or data from the Master fixture in a Master/Slave configuration) is lost. The choices are as follows:

### Instant

As soon as the control signal is lost, the fixture shuts off output and the LED array goes black.

### HLL-2Min

Hold last look for 2 minutes. The fixture retains its last setting for 2 minutes after the control signal is lost, after which it shuts off output.

Cycling power to the fixture before the 2 minutes have passed will clear the last look and the LEDs will remain off until control signal is restored.

### HLL-4ever

Hold last look forever. After data is lost, the fixture maintains its last look until power is removed from the fixture or control signal is restored. The last look will not be restored after power has been cycled.

- 1: On the **DMX Settings** menu, scroll to **Data Loss**.

DMX Settings	
DMX Start Address:	101
DMX Profile:	HSIC
Strobe:	On
<b>Data Loss:</b>	Instant
Plus Seven:	On
DMX Profile:	6 chan
2/15 Hue Fine	

Figure-4.8 Setting the Data Loss Type on the DMX Settings Menu

- 2: Press [**Enter**] to toggle through the three options.
- 3: Press [**▲▲▲**] or [**▼▼▼**] to commit the option.

## Plus Seven (Vivid, Lustr+, Fire and Ice, Studio HD)

Plus Seven adds precision color-control override channels to the HSI, HSIC, RGB, and Studio profiles. When in one of the above profiles, enabling Plus Seven adds an additional seven channels to the profile (e.g., a D40 fixture in HSI with Plus Seven becomes a 14-channel profile.) To enable Plus Seven, place the Plus Seven Control channel at a value above 51%.

When using Plus Seven, the desired color and intensity is selected by using the HSI or RGB channels as a starting point. From there, the additional seven channels represent an individual control channel for each of the native LED colors of the fixture and allow you to adjust each LED color up or down to fine-tune the overall color output.

The D60 fixture Plus Seven channels are different from the D22 and D40. For more information, see [DMX Footprints and Channel Mapping](#) on [page 32](#).

The first additional channel is an activation channel for the Plus Seven function. A value of 0 to 50% (DMX 0 to 128) deactivates Plus Seven. A value of 51 to 100% (DMX 129 to 255) activates Plus Seven. The remaining 7 additional channels correspond to the individual colors within the fixture's LED array.

- 1: On the **DMX Settings** menu, scroll to **Plus Seven**.

DMX Settings	
DMX Start Address:	101
DMX Profile:	HSIC
Strobe:	On
Data Loss:	Instant
<b>Plus Seven:</b>	On
DMX Profile:	6 chan
	1/15 Hue Coarse

Figure-4.9 Enabling Plus Seven on the DMX Settings Menu

- 2: Press [**Enter**] to toggle between **On** and **Off**.
- 3: Press [**▲▲▲**] or [**▼▼▼**] to commit the option.

## Using Plus Seven Control

- 1: On your lighting console, select a starting color point for the fixture output using the standard control channels for RGB, HSI, etc.
- 2: Set the first additional channel to a value between 51 and 100% to activate Plus Seven.
- 3: Refine the fixture output by altering one or more of the 7 individual color channels.
  - The starting point for each color is defined by the original color selection in step 1.
  - The brightness of each color can be increased or decreased from the starting point to any value between zero and full output.
  - Colors already at full output will not change when the Plus Seven channels are moved up from the starting point, and colors already at zero output will not change when the Plus Seven channels are moved down from the starting point.
  - The starting point on the Plus Seven color channels is 50% control level. If all the Plus Seven color adjust channels are at 50%, the colors are at the original colors.



**Note:** *Once any one of the seven individual color channels is altered from its neutral starting position, the settings for the original color point may no longer reflect the actual output of the fixture.*

*When using RGB, HSI, HSL, or Studio profile for color selection, each fixture makes accommodations for the specific LEDs in its array and produces output that is consistent with other fixtures, whether or not they use LEDs from the same production batch.*

*Operating with Plus Seven enabled can override this calibration, and multiple fixtures may produce slightly different outputs when individual color channels are altered from their neutral starting points.*

## LED Settings

Use the LED Settings menu to adjust fixture performance. From the LED Settings menu, you can set the following.

- Output
- Curve
- Output Frequency
- Red Shift
- White Point

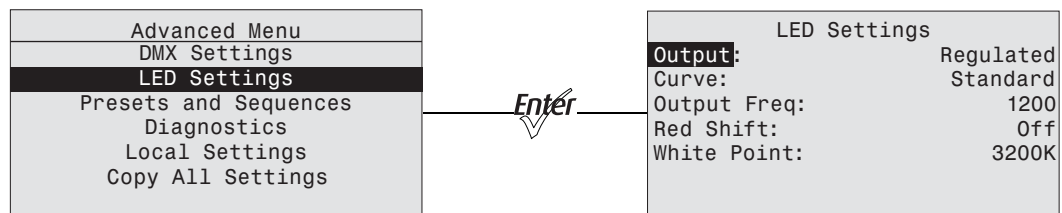

Figure-4.10 Selecting LED Settings on the Advanced Menu

## Output

Use Output to choose the optimal balance between two competing performance parameters, maximum brightness and output consistency, by adjusting:

- How much the fixture limits the overall power to the LED array.
- How the fixture reduces output as internal fixture components heat up during use or in high ambient temperatures.

The output options are described in the following sections.

### Regulated

Regulated is a moderately constrained power or brightness with consistent output under typical use. Power to the LEDs is separately regulated in order to maintain consistent brightness during the initial fixture warm-up period. This is recommended for most indoor applications.

### Protected

Protected provides the most consistent output possible with the greatest potential for reduced overall brightness. This is best for outdoor use, changing environmental temperatures, and applications with high requirements for consistency in extreme operating conditions.

## Boost

Boost provides the brightest possible output with the least guarantee of consistency. This is best for applications with low duty cycles, loose brightness requirements, or where ambient temperature is low.

- 1: On the **Advanced Menu**, scroll to **LED Settings**.
- 2: Press **[Enter]**.
- 3: With **Output** selected, press **[Enter]** to toggle between the options.
- 4: Press **[▲▲▲]** or **[▼▼▼]** to commit the option.



**Note:** *In all Output settings, if the fixture gets too warm and internal components approach unsafe operating temperatures, the total power to the LED array is gradually reduced and proportionate brightness levels between the various colors of LEDs are maintained as much as possible in order to preserve the overall color mix; however, some minor shifts in output may occur. Power continues to ramp down as much as necessary until internal fixture components return to a safe temperature. The fixture displays a warning message on the home screen indicating that power budgeting is in place, showing the percent of total power that is currently used.*

*If the fixture exceeds its maximum internal temperature, the fixture enters a cool-down state, stops responding to the control signal, shuts down most or all power to the LED array, and displays its over-temperature status according to its setting for over-temperature warning.*

## Curve

The dimming curve, commonly called curve, is the correlation between the change in the value of the dimming control signal and the actual change in the fixture's brightness. Curve is also the extent to which the fixture lags in its response time to the control signal in order to facilitate smoothness in dimming.

### Standard

Standard is a modest curve for intuitive brightness changes at both high and low ends of the dimming range. Standard provides moderate lag in response for good smoothness. It allows quick jumps in brightness. Suitable for most applications.

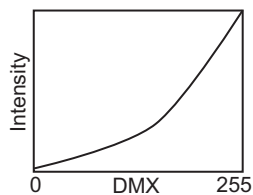

### Incandescent

Exaggerated curve mimics the response of tungsten on a conventional dimmer. Lag is quite pronounced and present even in full on or off bumps. Incandescent provides extreme smoothness with no instant changes. Best when fixtures must operate in sync with incandescent sources.

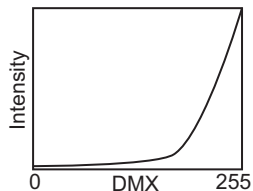

## Linear

Linear has no curve. Brightness levels correlate exactly with the value of the dimming control signal. Linear provides moderate lag in response for good dimming smoothness. Linear allows quick jumps in brightness. It is best for studio lighting and applications with static scenes or looks.

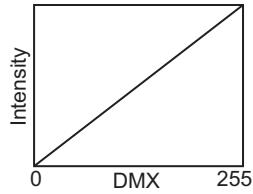

## Quick

Quick uses the standard dimming curve but with no lag or smoothing. All changes are instant and correlated exactly with the control input signal. Quick is best for extreme high impact and video-based control.

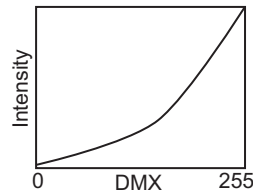

1: On the **LED Settings** menu, scroll to **Curve**.

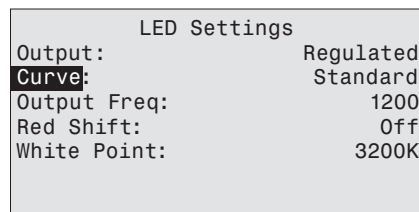

Figure-4.11 Selecting Curve on the LED Settings Menu

2: With **Curve** selected, press **[Enter]** to toggle between the options.

3: Press **[▲▲▲]** or **[▼▼▼]** to commit the option.

## Output Freq

Output Frequency is the frequency in Hz at which the LED array pulses, or blinks, as a function of Pulse-Width Modulation (PWM). The frequency is adjustable in order to avoid visible flicker on video and film. When altering the frequency in order to reduce noticeable flicker on camera, often only a small change is required. The range is 920 to 1500 Hz in increments of 10. The default value is 1200 Hz.

For high speed exposure or rolling shutter cameras, use the High 25K mode. This increases the PWM to 25,000 Hz and will result in flicker-free operation in most circumstances. To access the High 25K, press the up arrow after reaching 1500 Hz in the Output Freq: field.

Changing the frequency from the default value can have a slight impact on the smoothness, color-mix consistency, or both when dimming.

- 1: On the **LED Settings** menu, scroll to **Output Freq**.

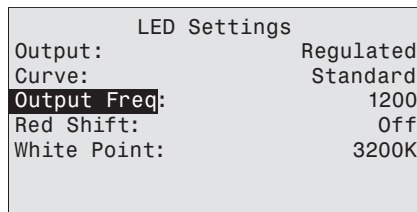

Figure-4.12 Selecting Output Frequency on the LED Settings Menu

- 2: Press **[Enter]** to select the value.
- 3: Press **[▲▲▲]** or **[▼▼▼]** to set the desired value.
- 4: Press **[Enter]**.
- 5: When asked if you are sure, select **Yes** and press **[Enter]**.

## Red Shift

Red shift allows the fixture to match its dimming performance to that of a conventional tungsten lamp. The fixture automatically changes its apparent White Point, or color temperature, as a function of overall intensity. Red shift works with both white-light and colored-light output settings. It is also known as amber drift and tungsten shift. Red shift is available only in the HSI and RGB profiles. It is not available on Studio Daylight and Studio Tungsten fixtures.

- 1: On the **LED Settings** menu, scroll to **Red Shift**.

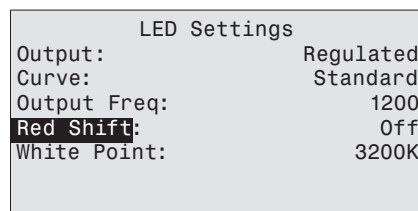

Figure-4.13 Selecting Red Shift on the LED Settings Menu

- 2: With **Red Shift** selected, press **[Enter]** to toggle between **On** and **Off**.
- 3: Press **[▲▲▲]** or **[▼▼▼]** to commit the option.



## White Point (Vivid, Lustr+, Fire and Ice, Studio HD)

White Point controls the appearance (color temperature) of white-light output when saturation is at or near zero. This option is available when using the HSI and RGB profiles. The choices are 2950 K, 3200 K, 5600 K, and 6500 K.

1: On the **LED Settings** menu, scroll to **White Point**.

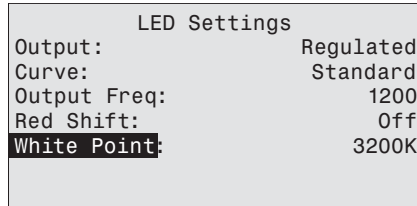

Figure-4.14 Selecting White Point on the LED Settings Menu

2: With **White Point** selected, press [**Enter**] to toggle between the options.

3: Press [**▲▲▲**] or [**▼▼▼**] to commit the option.

## Presets & Sequences

When no external control signal is connected to the fixture, the fixture can be set to run a preset color mix or a sequence of presets in a stand-alone operation. The fixture keeps the last preset or sequence active when power to the fixture is cycled on/off.

The Presets and Sequences screen provides access to the edit screens for Presets and for Sequences, and it indicates which Preset or Sequence is active, if any. You can access the Presets and Sequences menu by doing either of the following.

- On the **Advanced Menu**, scroll to **Presets and Sequences** and press [**Enter**].
- From any menu, except when operating in Studio profile, press [**☼**].



Figure-4.15 Selecting Presets and Sequences on the Advanced Menu

## Focus

Focus is independent of any of the other settings or presets and works whether or not the fixture is receiving DMX data from a console or is in a Preset or stand-alone state. Focus stays on until you disable it or power is disconnected. It turns every LED in the fixture on at 70% so you can:

- Focus (aim) the fixture prior to console setup or when there is no one at the console to give the fixture intensity.
- Double-check that the fixture is working and that all LEDs are operational.

1: From the **Advanced Menu** select **Presets and Sequences** or press [**☼**].

2: With **Focus** selected, press [**Enter**] to turn the fixture **On**.

3: When finished, press [**Enter**] to turn the fixture **Off**.

### ***Presets (Vivid, Lustr+, Fire and Ice, Studio HD)***

A Preset is a single, static look or color mix. The Desire Series fixtures come with 24 default configurations. Only one Preset can be active at a time. You can activate any of the Preset color mixes and customize each one. The following table lists the default Preset color mixes, most of which are also available as Quick Color options. See [Quick Color \(Vivid, Lustr+, Fire and Ice, Studio HD\)](#) on [page 64](#).

<b>Preset</b>	<b>Default Color</b>	<b>Available as Quick Color</b>
1	White	Yes
2	Warm	Yes
3	Cool	Yes
4	Minus Green	Yes
5	Lite Pink	Yes
6	Lite Gold	Yes
7	Yellow	Yes
8	Dark Straw	Yes
9	Dark Amber	Yes
10	Orange	Yes
11	Red	--
12	Med Pink	Yes
13	Dark Pink	Yes
14	Magenta	--
15	Purple	Yes
16	Dark Lavender	Yes
17	Deep Purple	Yes
18	Clear Blue	Yes
19	Lite Blue	Yes
20	Med Blue	Yes
21	Primary Blue	Yes
22	Blue-Green	Yes
23	Lite Green	Yes
24	Green	--

## Presets (Studio Daylight and Studio Tungsten)

The Desire Studio Daylight and Studio Tungsten fixtures come with 24 available slots for Presets. Only one Preset can be active at a time. You can activate any of the Presets and customize each one. Studio Daylight and Studio Tungsten fixtures have Presets that can define both Intensity and Strobe values. There are no default Presets that come pre-configured from the factory.



Figure-4.16 Selecting Presets on the Presets and Sequences Menu

- 1: On the **Presets and Sequences** menu, scroll to **Presets**.
- 2: Press **[Enter]**.
- 3: With **Preset** selected, press **[Enter]**.
- 4: Press **[▲▲▲]** or **[▼▼▼]** to set the desired preset number.
- 5: Press **[Enter]**.
- 6: Press **[▼▼▼]** to select **Status**.
- 7: Press **[Enter]** to activate the Preset.

The action changes to Active and an asterisk (\*) displays in front of the preset number.

### Fade Time

Fade time is the length of time the fixture takes to crossfade from the previous setting to the Preset. The format is MM:SS. The default is 2 seconds.

- 1: On the **Presets** menu, scroll to **Fade Time** and press **[Enter]**.

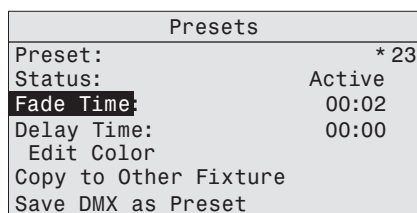

Figure-4.17 Selecting Fade Time on the Presets Menu

- 2: Press **[▲▲▲]** or **[▼▼▼]** to set the desired time in minutes.
- 3: Press **[Enter]**.
- 4: Press **[▲▲▲]** or **[▼▼▼]** to set the desired time in seconds.
- 5: Press **[Enter]**.

## Delay Time

Delay time is the length of time the fixture waits on the previous setting before initiating the crossfade to the Preset. The default is 0 seconds.

- 1: On the **Presets** menu, scroll to **Delay Time** and press **[Enter]**.

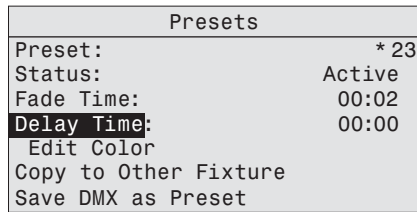

Presets	
Preset:	* 23
Status:	Active
Fade Time:	00:02
<b>Delay Time:</b>	00:00
Edit Color	
Copy to Other Fixture	
Save DMX as Preset	

Figure-4.18 Selecting Delay Time on the Presets Menu

- 2: Press **[▲▲▲]** or **[▼▼▼]** to set the desired time in minutes.
- 3: Press **[Enter]**.
- 4: Press **[▲▲▲]** or **[▼▼▼]** to set the desired time in seconds.
- 5: Press **[Enter]**.

## Edit (Vivid, Lustr+, Fire and Ice, Studio HD)

Use Edit to change the overall hue, saturation, intensity, and strobe settings of the Preset. You can change the predefined color mixes for the Preset. Refer to the table in [Presets \(Vivid, Lustr+, Fire and Ice, Studio HD\)](#) on [page 56](#).

To keep your changes, be sure to select **Save Changes** and then press **[Enter]**. To discard changes press **[<]** at any time.

If the Preset is currently active, the changes made on the Preset Color Edit screen update to the fixture output immediately.

- 1: On the **Presets** menu, scroll to **Edit Color** and press **[Enter]**.

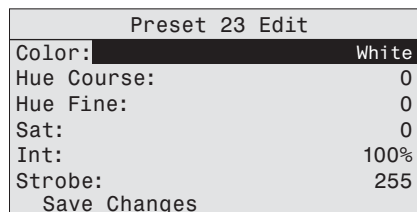

Preset 23 Edit	
<b>Color:</b>	White
Hue Course:	0
Hue Fine:	0
Sat:	0
Int:	100%
Strobe:	255
Save Changes	

Figure-4.19 Edit Preset Screen (Vivid, Lustr+, Fire and Ice, Studio HD)

- 2: With **Color** selected, press **[Enter]**.
- 3: Press **[▲▲▲]** or **[▼▼▼]** to set the desired predefined color mix.
- 4: Alternatively, to edit the predefined color mix, scroll to any of the parameters on the screen and press **[Enter]**.
- 5: Press **[▲▲▲]** or **[▼▼▼]** to change the values.
- 6: Press **[Enter]**.
- 7: Do one of the following:
  - Scroll to **Save Changes** and press **[Enter]**.
  - Press **[<]** to exit the screen without saving the changes.

## Edit (Studio Daylight and Studio Tungsten)

Use Edit to change the brightness and strobe settings of the LED array.

To keep your changes, be sure to select **Save Changes** and then press **[Enter]**. To discard changes press **[ < ]** at any time.

If the Preset is currently active, the changes made on the Preset Edit screen update to the fixture output immediately.

- 1: On the **Presets** menu, scroll to **Edit** and press **[Enter]**.

Preset 23 Edit	
Preset:	23
<b>Int:</b>	100%
Strobe:	0
Save Changes	

Figure-4.20 Edit Preset Screen (Studio Daylight and Studio Tungsten)

- 2: Scroll to any of the parameters on the screen and press **[Enter]**.
- 3: Press **[▲▲▲]** or **[▼▼▼]** to change the values.
- 4: Press **[Enter]**.
- 5: Do one of the following:
  - Scroll to **Save Changes** and press **[Enter]**.
  - Press **[ < ]** to exit the screen without saving the changes.



**Note:** *If a Preset is edited, it must be copied to other fixtures in the data chain and reactivated before the changes will take effect. If the Preset is not copied, the changes will not carry over to other fixtures and the same Preset number will produce different looks across fixtures in the chain.*

## Copy to Other Fixtures

If other fixtures are connected to the same data chain, you can copy the Preset values to the other fixtures. The fixture automatically becomes the Master and controls all the other fixtures (Slaves) in the chain until another fixture has its Preset or Sequence settings selected or activated. For more information, see [Master/Slave Operation](#) on [page 65](#).

- 1: On the **Presets** screen, scroll to **Copy to Other Fixtures**.

Presets	
Preset:	* 23
Status:	Active
Fade Time:	00:02
Delay Time:	00:00
Edit Color	
<b>Copy to Other Fixture</b>	
Save DMX as Preset	

Figure-4.21 Copy the Preset to Other Fixtures

- 2: Press **[Enter]**.
- 3: When asked if you are sure, select **Yes** and press **[Enter]**.

## Save DMX as Preset

You can take a snapshot of the incoming DMX signal when the fixture is in HSI mode and save it as a preset value.

- 1: On the **Presets** screen, scroll to **Preset** and press **[Enter]**.

Presets	
Preset:	* 23
Status:	Active
Fade Time:	00:02
Delay Time:	00:00
Edit Color	
Copy to Other Fixture	
<b>Save DMX as Preset</b>	

Figure-4.22 Save the DMX as a Preset

- 2: With **Preset** selected, press **[Enter]**.
- 3: Press **[▲▲▲]** or **[▼▼▼]** to set the desired preset number.
- 4: Press **[Enter]**.
- 5: Scroll to **Save DMX as Preset** and press **[Enter]**.

## Sequences

A Sequence is a timed series of presets. Up to 12 different Sequences may be altered for Preset selections, crossfade rate, and link time. Only one Preset can be active at a time. The sequences can be copied to other fixtures in the same data chain.

You can create your own custom sequence that includes two or more Presets. For example, you may want to sequence through Presets 2, 4, 23, and 1, in that order. As you enter these into the sequence, you also can set the rate and link time for each step.

Presets and Sequences	
Focus:	Off
Presets	
<b>Sequences</b>	
Quick Color	
Preset 1 is Active	
No Sequence is Active	

**Enter**

Sequences	
<b>Sequence:</b>	*3
Action:	Not Active
Rate:	100%
Step:	01
Preset:	1
Link Time:	00:02
Copy to Other Fixture	

Figure-4.23 Selecting Sequences on the Presets and Sequences Menu

- 1: From the **Advanced Menu** select **Presets and Sequences** or press **[⚙️]**.
- 2: On the **Presets and Sequences** menu, scroll to **Sequences**.
- 3: Press **[Enter]**.
- 4: On the **Sequences** menu, with **Sequence** selected, press **[Enter]**.
- 5: Press **[▲▲▲]** or **[▼▼▼]** to set the desired Sequence number.
- 6: Press **[Enter]**.
- 7: Scroll to **Status**.
- 8: Press **[Enter]** to activate the Sequence.  
The screen changes to Active and an asterisk (\*) displays in front of the preset number.
- 9: Press **[▼▼▼]** to scroll to **Rate**.

## Rate

Rate is the execution of the Presets' Fade Times and Delay Times within the Sequence, relative to their settings within the actual Presets. The available Rate range is 2 to 500%. The default is 100%.

A Rate of 100% represents running the Sequence with timing exactly as specified within the Presets. A Rate above 100% represents running the Sequence with faster timing than specified within the Presets. For example, with a Rate of 200%, a Preset with a Fade Time of 6 seconds would actually be run within the Sequence in only 3 seconds.

A Rate below 100% represents running the Sequence with slower timing than specified within the Presets. For example, with a Rate of 50%, a Preset with a Fade Time of 6 seconds would actually be run within the Sequence in 12 seconds.

Any change to the Rate is updated live in the fixture memory. Pressing [ < ] does not undo a change to Rate.

- 1: On the **Sequences** menu, scroll to **Rate** and press [Enter].

Sequences	
Sequence:	* 3
Action:	Not Active
Rate:	100%
Step:	01
Preset:	1
Link Time:	00:02
Copy to Other Fixture	

Figure-4.24 Selecting Rate on the Sequences Menu

- 2: Press [▲▲▲] or [▼▼▼] to set the desired percent.
- 3: Press [Enter].
- 4: Press [▼▼▼] to scroll to **Step**.

## Step

Step refers to the number of the current step in the sequence. In our example, you select step 1. After setting the Preset and Link time, return to **Step** and select step 2. Repeat this process until you have entered all the steps in the sequence.

Any change to Step is updated live in the fixture memory. Pressing [ < ] does not undo a change to Step.

- 1: On the **Sequences** menu, scroll to **Step** and press [Enter].

Sequences	
Sequence:	*3
Action:	Not Active
Rate:	100%
Step:	01
Preset:	1
Link Time:	00:02
Copy to Other Fixture	

Figure-4.25 Selecting Step on the Sequences Menu

- 2: Press [▲▲▲] or [▼▼▼] to set the desired Step number.
- 3: Press [Enter].
- 4: Press [▼▼▼] to scroll to **Preset**.

## Preset

Preset is the number of a Preset, whether it is a predefined or a custom color mix.

- 1: On the **Sequences** menu, scroll to **Preset** and press [**Enter**].

Sequences	
Sequence:	*3
Action:	Not Active
Rate:	100%
Step:	01
<b>Preset:</b>	1
Link Time:	00:02
Copy to Other Fixture	

Figure-4.26 Selecting Preset on the Sequences Menu

- 2: Press [**▲▲▲**] or [**▼▼▼**] to set the desired Preset number.
- 3: Press [**Enter**].
- 4: Press [**▼▼▼**] to scroll to **Link Time**.

## Link Time

Link Time is the length of time the fixture waits before moving from one Preset to the next. The format is MM:SS. The default is 2 seconds.

- 1: On the **Sequences** menu, scroll to **Link Time** and press [**▼▼▼**].

Sequences	
Sequence:	*3
Action:	Not Active
Rate:	100%
Step:	01
Preset:	1
<b>Link Time:</b>	00:02
Copy to Other Fixture	

Figure-4.27 Selecting Link Time on the Sequences Menu

- 2: Press [**▲▲▲**] or [**▼▼▼**] to set the desired time in minutes.
- 3: Press [**Enter**].
- 4: Press [**▲▲▲**] or [**▼▼▼**] to set the desired time in seconds.
- 5: Press [**Enter**] to commit the values.

## Finishing the Sequence

After each of the steps have been configured, set the End State. End state is what the fixture does once it completes the Sequence. Two end state options are available and both options repeat indefinitely until the Sequence is deactivated. To access the end state options, you must first program an additional and final step within the sequence using Preset 0. Preset 0 marks the end of the Sequence and opens the End State menu line. Preset 0 may only be used once within a Sequence. If you want the Sequence to repeat automatically, you may only define up to 23 steps with Presets 1 through 24, since the final step must be reserved for Preset 0.



## Loop

Once the fixture completes the entire sequence, it immediately returns to the beginning and starts the sequence over again, in order.

## Bounce

Once the fixture completes the entire sequence, it reverses the order of the presets and steps backward through them until reaching the starting step, at which point it starts the Sequence over again, in the original order.

Sequences	
Sequence:	* 3
Status:	Active
Rate:	100%
Step:	01
Preset:	0
End State:	Loop
Copy to Other Fixture	

Figure-4.28 Setting Sequence End State

- 1: On the **Sequences** menu, scroll to **Preset** and press **[Enter]**.
- 2: With the Preset number selected Press **[▲▲▲]** or **[▼▼▼]** until you reach **0**.
- 3: Press **[Enter]**.  
Link Time on the screen is replaced with End State.
- 4: Scroll to **End State** and press **[Enter]** to toggle between the options.
- 5: If the Sequence is not active, scroll up to **Status** and press **[Enter]**.

## Copy to Other Fixtures

If other fixtures are connected to the same data chain, you can copy the Sequences settings to the other fixtures. The fixture automatically becomes the Master and controls all the other fixtures (Slaves) in the chain until another fixture has its Preset or Sequence settings selected or activated. For more information, see [Master/Slave Operation](#) on [page 65](#).

- 1: On the **Sequences** screen, scroll to **Copy to Other Fixtures**.

Sequences	
Sequence:	* 3
Status:	Active
Rate:	100%
Step:	01
Preset:	0
End State:	Loop
Copy to Other Fixture	

Figure-4.29 Selecting Copy to Other Fixtures.

- 2: Press **[Enter]**.
- 3: When asked if you are sure, select **Yes** and press **[Enter]**.



**Note:** *This option only copies Sequence data; it does not copy changes to the Preset settings or color mixes used within the Sequence.*

## Quick Color (Vivid, Lustr+, Fire and Ice, Studio HD)

Quick Color allows you to easily select a color and its intensity from a predefined menu. This feature overrides any presets or sequences previously selected and is only available when there is no external DMX signal to the fixture. For a list of available colors, see the table on [page 56](#).



**Note:** *Exiting the Quick Color menu will return the fixture to the state it was in before entering the menu.*

- 1: Press the [] to quickly access the **Presets and Sequences** screen.
- 2: Within the **Presets and Sequences** screen, scroll to **Quick Color**.
- 3: Press [].

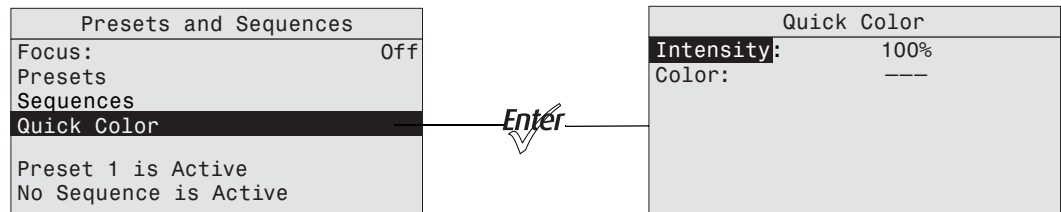

Figure-4.30 Selecting Quick Color on the Presets and Sequences Menu

- 4: Scroll to **Color** and press [].
- 5: Press [] or [] to select the desired color.
- 6: Press [] to commit the selection.
- 7: Scroll to **Intensity** and press [].
- 8: Press and hold [] or [] to adjust the fixture's intensity.
- 9: Press [] to commit the selection.
  - To set the Intensity to 0, press the []. Pressing [] a second time will return the fixture to its previously set Intensity.
  - If power to the fixture is lost while in Quick Color mode, the fixture will return to the Quick Color menu once power is restored.

## Master/Slave Operation

When similar fixtures' DMX or data connections are linked together and there is no external DMX signal going to them, one fixture automatically controls all other fixtures in the chain when a Preset, Sequence, or Quick Color is initiated.

### Master

Master is the one fixture that controls all fixtures in the daisy chain. By default, it is whichever fixture had its Preset, Sequence, or Quick Color selected or adjusted most recently. The Master fixture can only control Slave fixtures to produce identical output at the same time as itself. The Master fixture cannot control Slave fixtures to operate individually or to run chase-type or time-offset sequences.

Changes and edits to Presets or Sequences that are made to the Master fixture may be copied to the internal memory of all Slave fixtures for later use when these fixtures are disconnected from the data daisy chain.

When operating as the Master fixture, the fixture displays Master on its home screen.

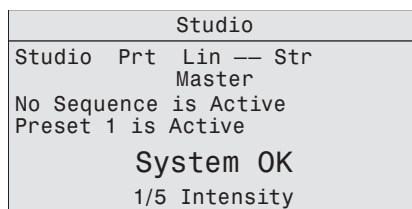

Figure-4.31 XYZ Status Screen Showing Master

### Slave

A slave is any fixture in the data chain that is being controlled by the master fixture. By default, all fixtures are slaves, except the one that had its Preset, Sequence, or Quick Color altered most recently. A Slave fixture can only directly imitate the performance of the Master fixture.

When operating as a Slave fixture, the fixture displays Slave on its home screen.

## Diagnostics

The Diagnostics menu provides access to detailed information about various aspects of the fixture's performance. Diagnostics also provides access to test functions and fixture recalibration. Much of the Diagnostics menu is used by service technicians to troubleshoot problems.

- 1: From the home screen, press [*Enter*] to open the **Main Menu**.
- 2: Scroll to **Advanced Settings**.
- 3: Press [*Enter*].

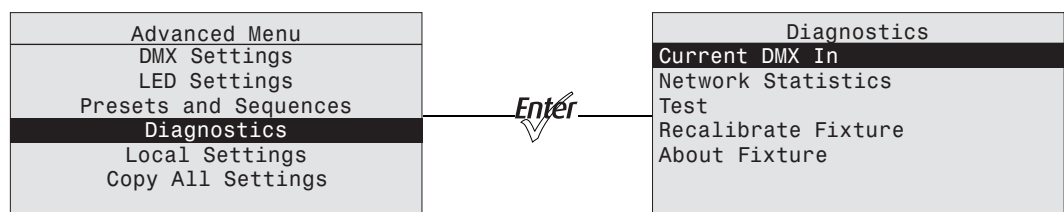

Figure-4.32 Selecting Diagnostics on the Advanced Menu

## Current DMX In

The Current DMX In screen displays the values of the current DMX input by channels. The values dynamically change as the DMX input changes. This screen is a read-only screen, which displays the following:

- The Control Input setting
- The DMX channel assignment, in order
- The current DMX value (0–255) of each control channel in use by the fixture
- The current brightness (0 to full or 00 to FL) of each series of LEDs in the fixture's LED array

1: On the **Diagnostics** screen, scroll to **Current DMX In**.

2: Press **[Enter]**.

Current DMX In						
DMX Ch						Level
↑ 2						107
3						14
4						82
↓ 5						0
G	0	R	A	0	R	I
11	02	00	10	00	00	01

Labels in the image: **DMX channel** points to the DMX Ch column; **LED series** points to the G, 0, R, A, 0, R, I row; **DMX value** points to the Level column; **Brightness** points to the 11, 02, 00, 10, 00, 00, 01 row.

Figure-4.33 Current DMX In Screen with Dynamic Values

3: Press **[▲▲▲]** or **[▼▼▼]** to scroll through the channels. Arrows on the left indicate that you can scroll up or down.

4: Press **[ < ]** to return to the Diagnostics screen.

## Network Statistics

The Network Statistics screen displays the statistics of the network. The DMX input values dynamically change. This screen is read-only.

1: On the **Diagnostics** screen, scroll to **Network Statistics**.

2: Press **[Enter]**.

When you access the screen, the dynamic values start at 0 and continue to increase.

Diagnostics	
Network Statistics	
Overruns:	0
Received:	47835
Breaks:	15490
Bad Starts:	0
DMX Starts:	27120
RDM Starts:	0

Figure-4.34 Network Statistics Screen with Dynamic Values

3: To reset the counters, press **[Enter]**.

4: Press **[ < ]** to return to the Diagnostics screen.

## Test

Test is used to test the fixture and display its output values. Test overrides all other control to the fixture. The action options are All Off, All On, Chase, and Ind Cntl (Individual control). The default is All Off.

To exit the Test screen, press [ < ] twice. The fixture will revert to its previous state.

- 1: On the **Diagnostics** screen, scroll to **Test**.
- 2: Press [Enter].

Diagnostics						
Test						
<b>Action:</b>						
Chase: 15 steps/sec						
Individual Control						
G	O	R	A	O	R	I
00	00	48	00	00	00	00

Figure-4.35 Test Screen in Chase Mode

- 3: With **Action** selected, press [Enter] to toggle between the options.
- 4: Press [▲▲▲] or [▼▼▼] to commit the option.

## Chase

Chase automatically sequences through each LED color and starts each at 0% intensity and steps up to 100% before moving to the next color. You can set the number of steps per second for sequencing through all LED colors individually.

- 1: On the **Test** screen, scroll to **Action**.
- 2: Press [Enter] until the **Chase** option displays.  
The fixture begins to sequence through the LEDs.
- 3: Press [▼▼▼] to select **Chase**.
- 4: Press [Enter] to select the values.
- 5: Press [▲▲▲] or [▼▼▼] to set the number of steps per second.  
The range is 10 to 20.
- 6: Press [Enter] to commit the value.  
The percent of intensity is displayed for each color as the fixture sequences through them.
- 7: To stop the test, do one of the following:
  - Press [▲▲▲] or [▼▼▼] to select **Action** and then press [Enter] until **All Off** displays.
  - Press [ < ] to return to **Action** and then press [Enter] until **All Off** displays.

## Individual Control (Ind Cntl)

Use Individual Control to select each LED series and then adjust its intensity.

- 1: On the **Test** screen, scroll to **Action**.
- 2: Press **[Enter]** until the **Ind Cntr** option displays. One of the LED series will illuminate.
- 3: Press **[↓]** to select the series.

Diagnostics						
Test						
Action:				Ind Cntr		
Chase:				15 steps/sec		
Individual Control						
G	O	R	A	O	R	I
56	00	00	00	00	00	00

Figure-4.36 Test Screen in Individual Control Mode

- 4: Press **[↑]** or **[↓]** to set the intensity of the series.
- 5: Press **[Enter]** to move to the next series.  
The value you entered for the first series is applied to the next series.
- 6: Press **[↑]** or **[↓]** to change the intensity of the series.
- 7: Press **[ < ]** to return to **Action**.

## Recalibrate Fixture

Service technicians may use this option to calibrate the constant current driver electronics for the LEDs. The calibration process goes through each series of LEDs, starting at 0 intensity and stepping up to 100%. The calibration is automatic and takes less than a minute. During this time, do not exit the screen until it is complete.



**CAUTION:** *This calibration process does not measure or recalibrate the light output of the LEDs.*

*Under normal use, it is not necessary to recalibrate the fixture, and doing so will likely have no beneficial effect on fixture performance. It is therefore NOT recommended to recalibrate the fixture without express instruction from an authorized technician.*

- 1: On the **Diagnostics** screen, scroll to **Recalibrate Fixture**.
- 2: Press **[Enter]**.
- 3: When asked if you are sure, select **Yes** and press **[Enter]**.  
A new screen shows that the calibration is in progress and whether the LEDs pass the calibration.



Figure-4.37 LED Calibration Screen with Calibration in Process

- 4: Press **[Enter]** or **[ < ]** to return to the **Diagnostics** screen.

## About Fixture

The About screen displays the following information. This is a read-only screen.

- The software version number
- The fixture serial number
- The assigned fixture RDM number and label
- The fixture model

About Fixture
DMX START: 001
Ver: 1.5.0.0.0.05 (0)
Ser: 000021xxx
RDM: 6574:12345678
Desire Lustr+ 22
RDM Label

Figure-4.38 About Fixture Screen

- 1: On the **Diagnostics** screen, scroll to **About Fixture**.
- 2: Press **[Enter]**.
- 3: Press **[Enter]** or **[ < ]** to return to the **Diagnostics** screen.

## Local Settings

The Local Settings menu gives you several options that affect the LCD and other functions of the fixture.



Figure-4.39 Selecting Local Settings on the Advanced Menu

- 1: On the **Advanced Menu**, scroll to **Local Settings**.
- 2: Press **[Enter]**.
- 3: Scroll to any of the menu choices and press **[Enter]**.

## Backlight

You can change the brightness of the LCD backlight. The brightness level is 10 to 100%. The default is 100%.

- 1: With **Backlight** selected, press **[Enter]** to select the value.
- 2: Press **[▲▲▲]** or **[▼▼▼]** to set the desired brightness percentage. The effect can be seen as you make the adjustment.
- 3: Press **[Enter]**.

## ***BLght time out***

You can change the length of time the LCD backlight remains on after a UI button has been pressed. The options are 30 seconds, 1 minute, 5 minutes, 15 minutes, and never. The default is 1 minute.

1: With **BLght time out** selected, press **[Enter]**.

Local Settings	
Backlight:	100%
<b>BLght time out:</b>	1 min
Language:	English
Status Indicators:	Off
OverTemp:	Visible
Restore Defaults	

Figure-4.40 Setting Backlight Timeout

2: Continue to press **[Enter]** until the desired time is indicated.

3: Press **[▲▲▲]** or **[▼▼▼]** to commit the option.

## ***Language***

The screen language is English.

Local Settings	
Backlight:	100%
BLght time out:	1 min
<b>Language:</b>	English
Status Indicators:	Off
OverTemp:	Visible
Restore Defaults	

Figure-4.41 Screen Language Set to English

## ***Status Indicators***

You can turn the status indicators on or off. The default is on.

1: With **Status Indicators** selected, press **[Enter]**.

Local Settings	
Backlight:	100%
BLght time out:	1 min
Language:	English
<b>Status Indicators:</b>	Off
OverTemp:	Visible
Restore Defaults	

Figure-4.42 Setting the Status Indicator Display

2: Continue to press **[Enter]** to toggle between ON and OFF.

3: Press **[▲▲▲]** or **[▼▼▼]** to commit the option.



**CAUTION:** *Although it may be desirable in some applications to eliminate all stray light from the back of the fixture, turning the Status Indicators OFF prevents them from communicating potentially critical information. Use discretion when selecting the OFF setting.*



## OverTemp

You can change how an over-temperature situation is indicated in order to control stray light.

### Visible (Vivid, Lustr+, Fire and Ice, Studio HD)

The fixture produces a low-level, red light from the LED array, displays a warning message on the LCD, turns on the LCD backlight, and turns on the error indicator light.

### Visible (Studio Daylight and Studio Tungsten)

The fixture produces a low-level light from only some of the LEDs in the LED array, displays a warning message on the LCD, turns on the LCD backlight, and turns on the error indicator light.

### Dark

The fixture turns off the LED array entirely and displays a warning message on the LCD without turning on the LCD backlight.

1: With **OverTemp** selected, press **[Enter]**.

Local Settings	
Backlight:	100%
BLght time out:	1 min
Language:	English
Status Indicators:	Off
<b>OverTemp:</b>	Visible
Restore Defaults	

Figure-4.43 Setting Over Temperature Indication

2: Continue to press **[Enter]** to toggle between the two options.

3: Press **[▲▲▲]** or **[▼▼▼]** to commit the option.

For more information, see [Thermal Shutdown Warning](#) on [page 45](#).



**Note:** *When returning to normal operation after the fixture has been in a shutdown status, the LED array automatically transitions its output back to the current control signal or stand-alone operation over a 10-second crossfade. There is no required reset function once the fixture temperature returns to a safe level.*

## Restore Defaults

You can restore the fixture to the factory settings. This function clears all custom settings including all changes to Presets and Sequences.

1: With **Restore Defaults** selected, press **[Enter]**.

2: When asked if you are sure, select **Yes** and press **[Enter]**.

3: Press **[Enter]**.

## Copy All Settings

When DMX is not applied you can copy all settings, except the DMX address, to all of the other fixtures in the same data chain in one step. This includes everything from Presets and Sequences to Quick Setups and Advanced options.

This feature is not available when the fixture is receiving an external DMX signal.

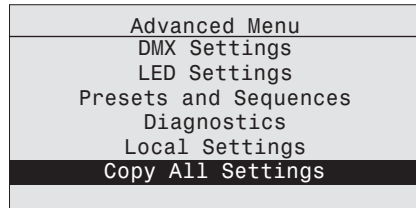

Figure-4.44 Copy All Settings on the Advanced Menu

- 1: With **Copy All Settings** selected, press **[Enter]**.
- 2: When asked if you are sure, select **Yes** and press **[Enter]**.
- 3: Press **[Enter]**.

## Studio Settings

### Vivid, Lustr+, Fire and Ice, Studio HD

The Studio profile produces only white light that is adjustable in brightness, white point, and tint (green/magenta balance). The Studio profile can be operated in a stand-alone mode from the user interface or can be controlled via DMX.



---

**Note:** *Studio profile is the default Quick Setup for fixtures containing the Studio HD LED array. Fixtures with other LED arrays may also be operated in Studio profile by selecting this setting from Quick Setups or DMX Settings. Fixtures with Studio HD LED arrays may also be operated in other setups.*

---

## Operation From Home Status Screen (Studio Stand-alone)

When operating without an external control signal, the quality of the white light can be adjusted immediately and directly via menu options on the home screen.

When fixtures are connected together and there is no external control signal, all adjustments that you make on one fixture are automatically made on the connected fixtures.

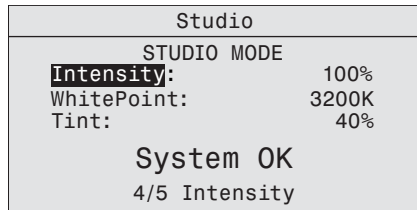

Figure-4.45 Studio Status Home Screen (Vivid, Lustr+, Fire and Ice, Studio HD)

- To adjust the Intensity, select it in the menu and press [Enter] and then [▲▲▲] or [▼▼▼]. The range is 0 to 100%.
- To immediately set the Intensity to 0, press the [☼] button. Pressing it again will return it to the previously-set Intensity.
- To adjust the White Point, select it in the menu and press [Enter] and then [▲▲▲] or [▼▼▼]. The range is 2700 to 6500 K.
- To adjust the Tint, select it in the menu and press [Enter] and then [▲▲▲] or [▼▼▼]. Pressing [▲▲▲] increases magenta and [▼▼▼] increases green.
- To return to the Main Menu, press [ < ].
- To return to the Studio status screen from the Main Menu, press [ << ].

## Studio DMX Control

When controlled via DMX, the first three channels adjust the output in the following order. Channel 5 controls strobe.

Channel	Output
1	Intensity (Brightness)
2	White Point
3	Tint
5	Strobe

When adjusting white point via DMX, the full gamut of 2725 to 6450 K is available, but common settings of 3200 K and 5600 K are quickly accessible at the lowest and highest pairs of DMX values, respectively. The range of control on channel 2 is distributed as follows.

DMX Value	White Point
000 to 001	3200 K
002 to 253	Adjustment from 2725 to 6450 K
254 to 255	5600 K

When adjusting tint via DMX, the range of control on channel 3 is distributed as follows.

DMX Value	Tint
000 to 001	Neutral white (at the specified white point)
002 to 127	Full plus-green to neutral white
128	Neutral white
129 to 255	Neutral white to full minus-green (full magenta)

Additional channels for other functions, such as strobe and Plus Seven, can also be activated, if desired, starting with channel 4.



**Note:** *When using DMX to control the fixture in Studio mode, the default data-loss behavior is different than in other operational modes. If the DMX signal is lost, the fixture automatically holds the last look forever (HLL-4ever). This look persists through infinite off/on power cycles until the DMX signal is restored or the fixture settings are adjusted manually via the user interface.*

*When powering down the fixture in Studio mode, continue to supply DMX to the fixture until after the fixture has powered down. If you power down the fixture before the fixture has finished saving the last look, the fixture may return to default settings when powered up again instead of holding the last look.*

## Studio Daylight and Studio Tungsten

The Studio profile allows quick adjustment of Intensity. The Studio profile can be operated in a stand-alone mode from the user interface or can be controlled via DMX.

### *Operation From Home Status Screen (Studio Stand-alone)*

When operating without an external control signal, the intensity of the white light can be adjusted immediately and directly by pressing the buttons on the fixture while on the home screen.

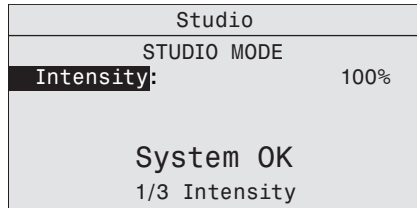

Figure-4.46 Studio Status Home Screen

- To adjust the **Intensity**, press [**Enter**] and then [**▲▲▲**] or [**▼▼▼**]. The range is 0 to 100%.
- To return to the Main Menu, press [**<<**].
- To return to the Studio status screen from the Main Menu, press [**<<**], [**<**], or allow the user interface to time out and automatically return to the status screen.

### *Studio DMX Control*

When controlled via DMX, the channels adjust the following.

Channel	Output
1	Intensity (Brightness)
2	Strobe
3	Fan (D60 only)

## Configure D60X using RDM

Up to 32 D60X fixtures can be daisy-chained on a DMX/RDM network. Each fixture can have an unique DMX address, and each address can be configured separately. Also, more than one fixture can have the same address, allowing you to configure fixtures identically.

You can use an RDM configuration tool or an RDM lighting control device to configure the fixtures. An RDM configuration tool is installed on a PC, which is connected to the DMX/RDM network via Gadget II or a DMX/RDM gateway. After the fixtures are configured, Gadget II or the gateway can be disconnected and a DMX or RDM control device can be connected to the network for continued operation.

See [Connect using Gadget II on page 77](#) or [Connect using a DMX/RDM Gateway on page 78](#).

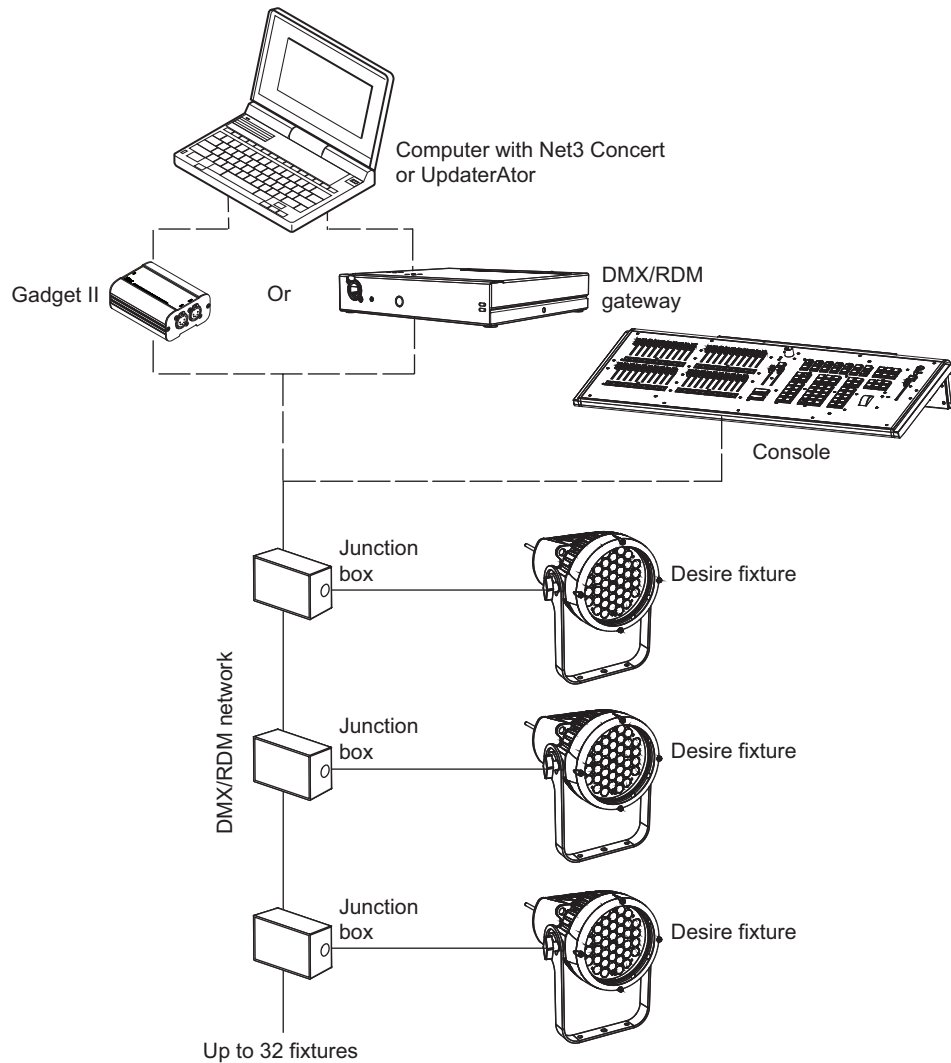

Figure-4.47 Architecture of a Desire series fixture network

## Connect using Gadget II

Gadget II provides a connection from a PC to your lighting system's DMX/RDM devices. Gadget II provides DMX control of level output, configuration, and monitoring for RDM devices including fixtures, dimmers, and more. You can also upgrade software for most DMX-based ETC products using UpdaterAtor or Net3 Concert software.

Prior to connecting Gadget II, start the RDM configuration tool and apply power to the fixtures.

For detailed information, see the *Gadget II USB to DMX/RDM Interface Setup Guide*.

- 1: Connect the USB cable to the PC and the mini USB to Gadget II.
- 2: Connect the DMX cable to Gadget II.
- 3: Connect the other end of the DMX cable to the DMX/RDM network jack.

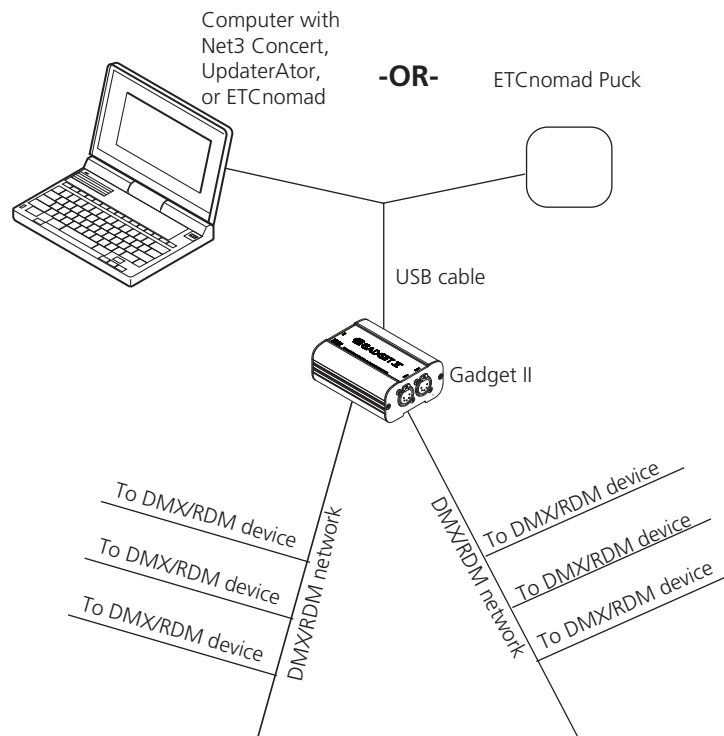

Figure-4.48 Gadget II architecture

Also see [Connect using a DMX/RDM Gateway](#) on [page 78](#).

For information on RDM commands, see [RDM Commands](#) on [page 91](#).

## Connect using a DMX/RDM Gateway

A DMX/RDM gateway, such as an ETC Gateway, can be used to connect a PC to the DMX/RDM network so that you can configure the fixtures on the network. The Gateway can be connected directly to a PC with an Ethernet cable.

Prior to connecting through a gateway, start the RDM configuration tool software and apply power to the fixtures.

1: Do one of the following:

- Connect the PC to the local area network via Ethernet and then use an RJ45 cable to connect the gateway to the same network.
- Using an RJ45 cable, connect the PC to the gateway.

2: Connect the DMX cable to the gateway.

3: Connect the other end of the DMX cable to the DMX jack that is connected to the DMX/RDM network.

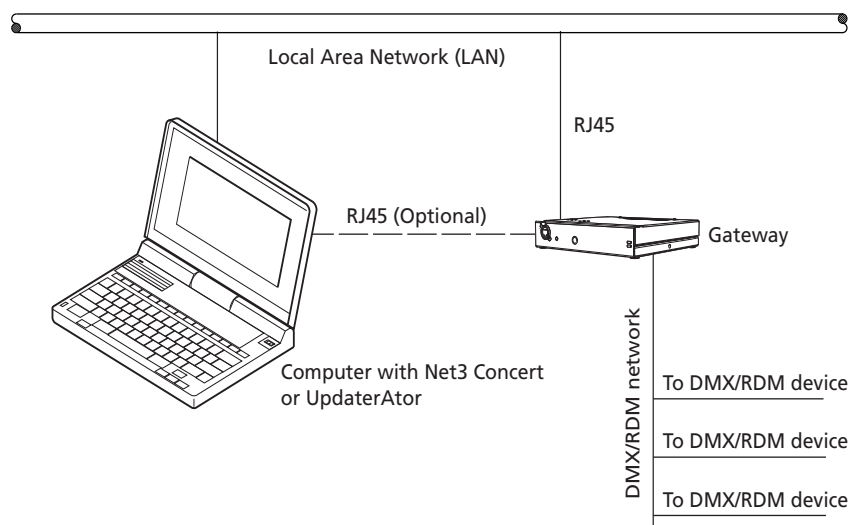

Figure-4.49 Gateway architecture

## Configuration

Use an RDM configuration tool to configure the Desire XTI Series fixtures. After you configure the fixtures and disconnect Gadget II or a DMX/RDM gateway, you may control the fixtures with a DMX or RDM lighting control device.

For detailed information about LED Config software, refer to the *LED Configuration Software Programming Guide*.

For information on RDM commands, see [RDM Commands](#) on [page 91](#).



## Error Messages

When a system error is detected, a message displays on the home screen. The message changes to reflect the specific error type. When multiple errors are detected, each error message cycles in increasing numerical order on the display for 1 second each. The following table lists the error messages.

Error Message	Description
LED Ambient Overtemp	The LED head ambient temperature is too high and the fixture has been shut down. Let the fixture cool.
LED Ambient High	The LED head ambient temperature is getting hot. Let the fixture cool.
LED Ambient Low	The LED head ambient temperature is too cold. Improper operating conditions.
Color System Fail	Fixture does not have its color information loaded. This error may represent a hardware failure. Contact ETC Technical Services.
LED Over Temp	A specific LED is too hot and the fixture has been shut down.
Internal Temp High	The fixture's internal temperature is too high.
Power Budget Active	The fixture is reducing the LED output due to high temperatures.
Internal Overtemp	The internal temperature of the fixture is too high, so the fixture has been shut down. Let the fixture cool.
Configuration Error	The stored configuration has been compromised. The fixture will return to a default configuration.

## Software Updates

The software for your Selador Desire fixture can be updated with UpdaterAto Software. UpdaterAto allows you to remotely update the fixture. UpdaterAto is installed on your computer and connected from the computer to the fixture with a special cable or through a gateway. For more information, contact ETC Technical Services or visit [etconnect.com](http://etconnect.com).

## ETC Technical Support

Any time, any day, 15 minute response time—that's our service commitment. ETC's Technical Service is unparalleled in the industry. With over 60 service employees worldwide, not to mention our extensive Authorized Service Center network, we are uniquely positioned to be able to help you anywhere, anytime. Call on our years of expertise for help with any lighting situation. Our commitment is to make your day shine brighter.

### Americas

608/831-4116 or toll-free in the U.S. at 800/688-4116

### Europe

(+44) 20 8896 1000

### Germany

(+49) 8024 4700-0

### Asia

(+852) 2799 1220

## Routine Maintenance

To ensure optimum performance of your Desire series fixture, you should perform the following inspections and cleaning at least once a year. You may need to inspect or clean the fixture more often, depending on the type and amount of use your fixture experiences during the year.



**CAUTION:** *Allow fixture to cool down completely prior to cleaning.*

*Disconnect all power and DMX cables prior to cleaning.*

*Check for excessive dust or debris in the heat-dissipating fins around the entire fixture enclosure. Clean using compressed air or a soft cloth. Keeping the components of the enclosure clean facilitates efficient cooling and extends LED longevity.*

*NEVER spray liquids into the fixture.*

*NEVER spray compressed air into a fixture that is powered-up.*

---

- A can of compressed air or oil-free air from an air compressor set at a low setting can be used to blow through the vent holes and remove dust or other debris from the interior of the fixture. Dust buildup can cause overheating and premature shutdown.
- Remove the secondary lenses (if used) and clean out any dust and debris. All components, including the secondary lenses, can be cleaned using compressed, oil-free air as described above or a clean micro-fiber cloth. The use of any liquid cleaning solution is not recommended for Desire fixtures.
- Inspect all mounting hardware for wear and, if necessary, clean using compressed, oil-free air or a soft, lint-free cloth.

# Appendix A

## Menu Flow Chart

---

The following illustrations show each of the menus that are displayed on the Desire fixture LCD and the path to each one. This menu does not apply to the D60X fixture.

### Home and Main Menus (Vivid, Lustr+, Fire and Ice, Studio HD)

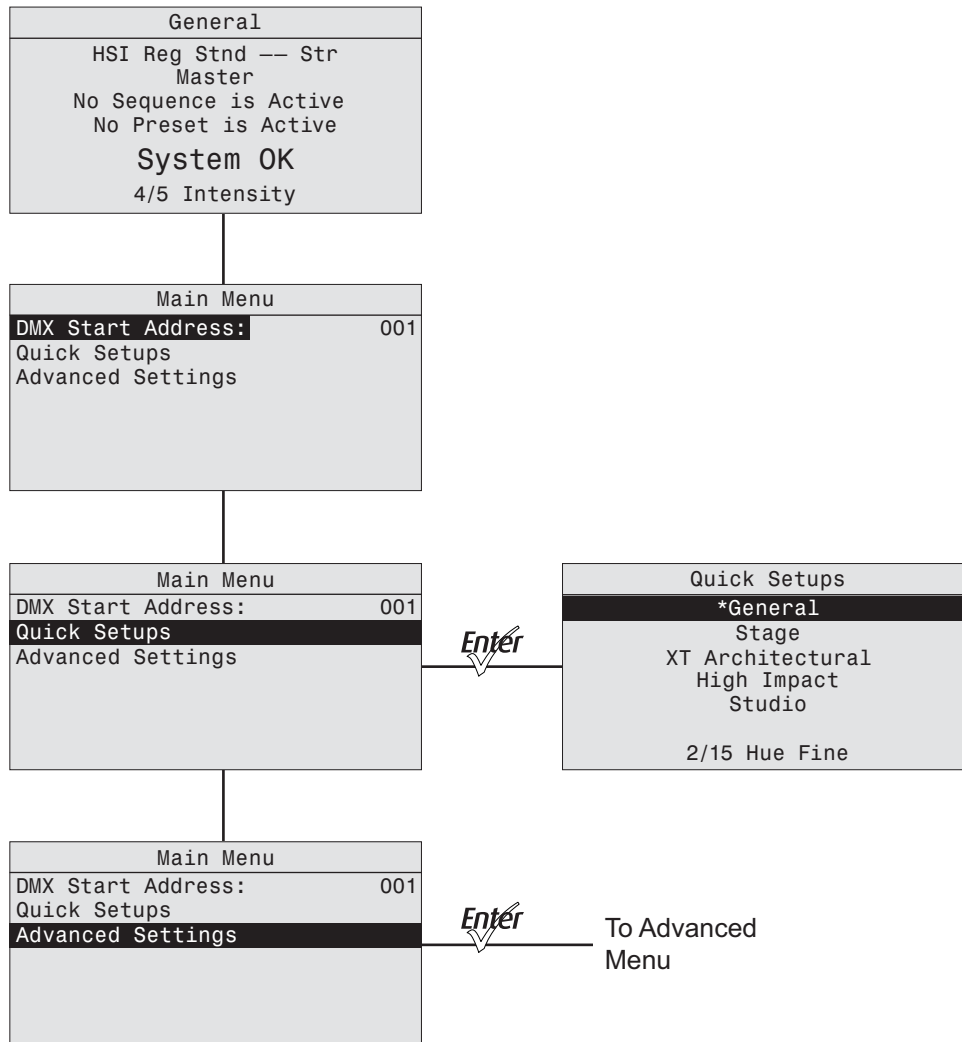

# Home and Main Menus (Studio Daylight and Studio Tungsten)

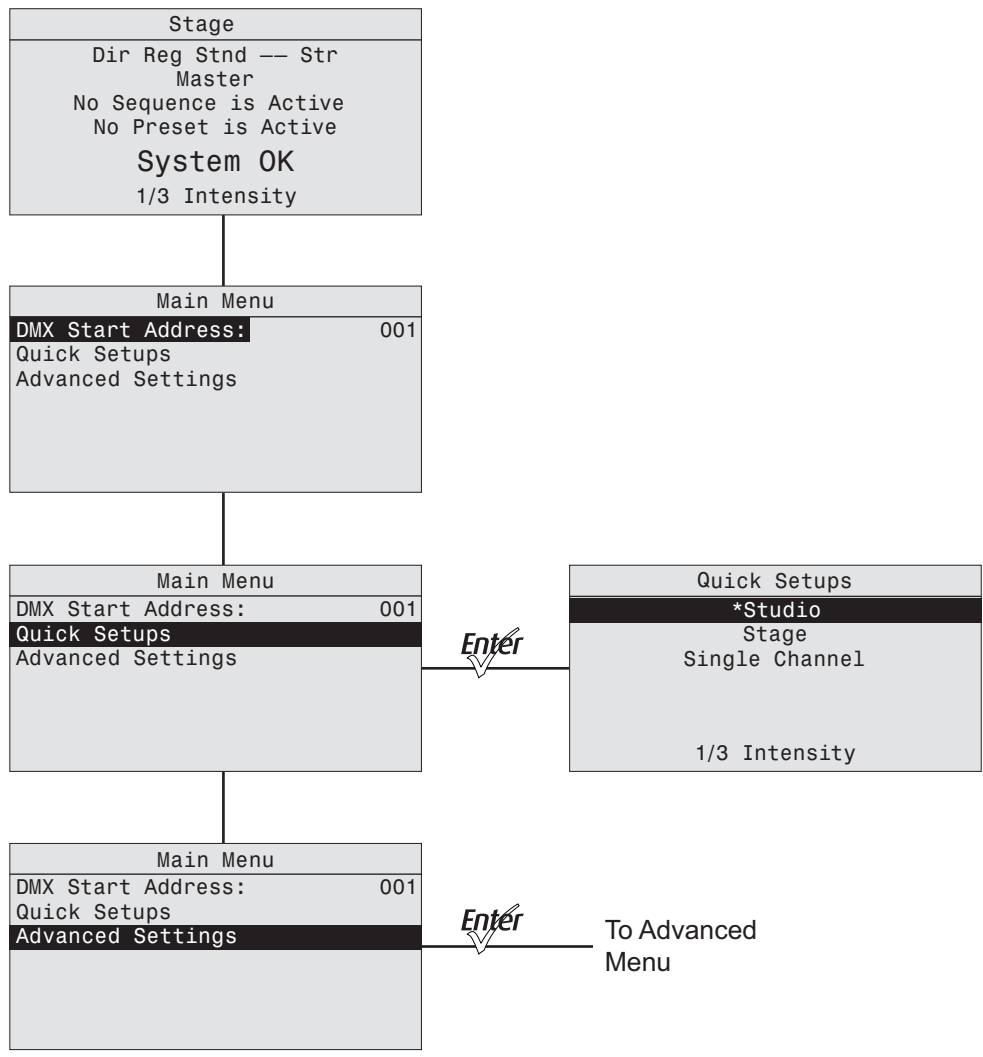

# Advanced Menu (Vivid, Lustr+, Fire and Ice, Studio HD)

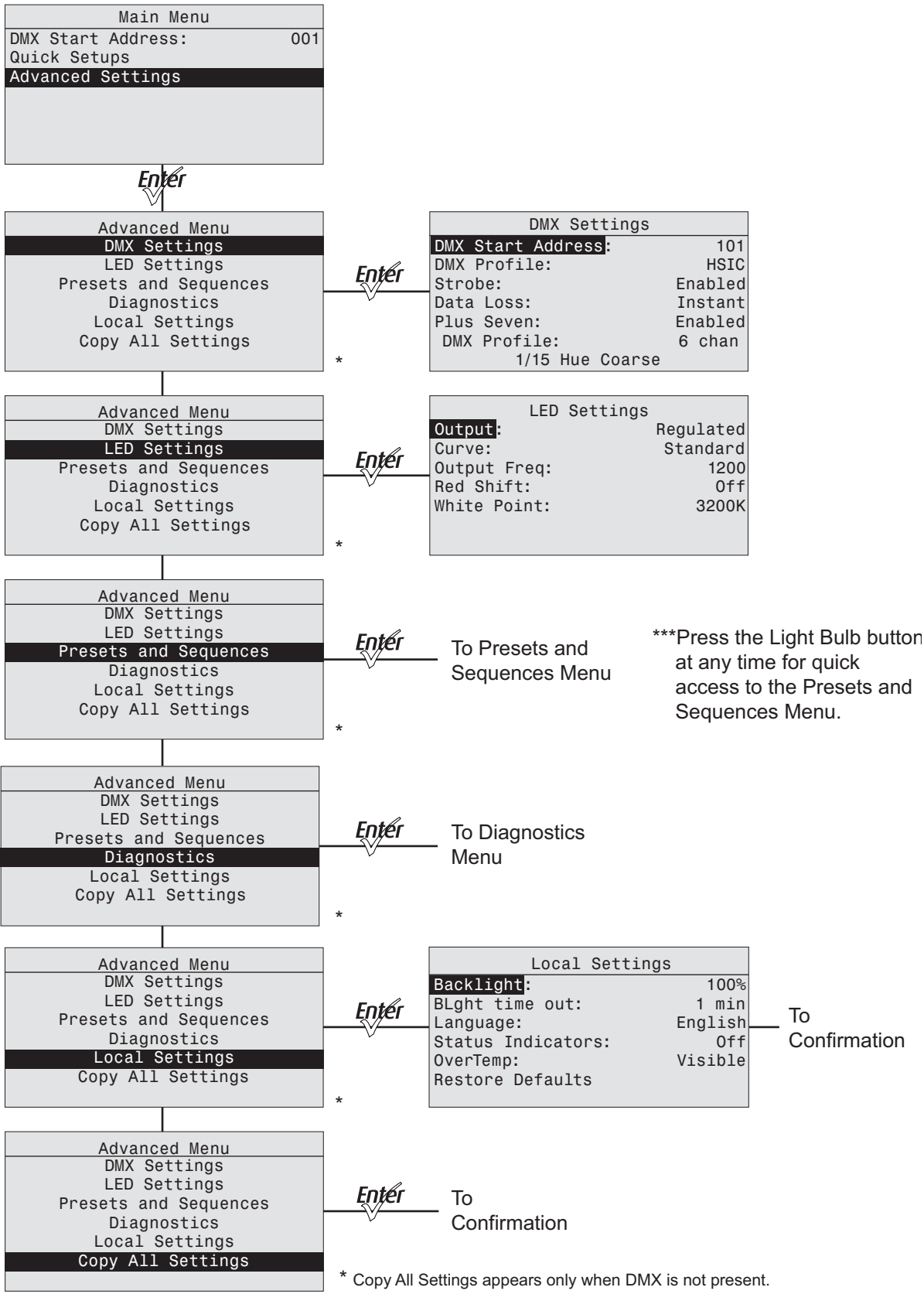

# Advanced Menu (Studio Daylight and Studio Tungsten)

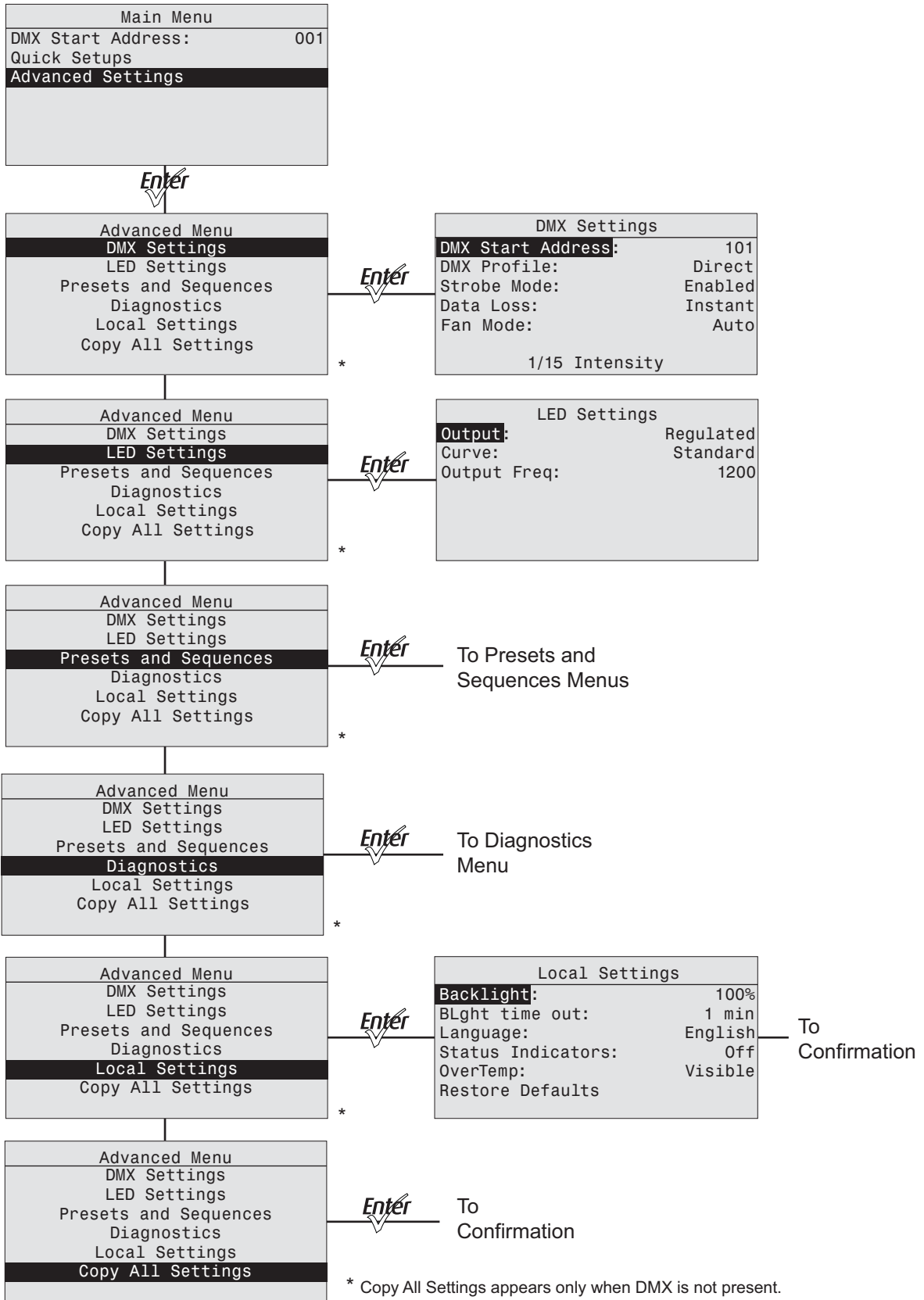

# Presets (Vivid, Lustr+, Fire and Ice, Studio HD)

\* Copy All Settings appears only when DMX is not present.

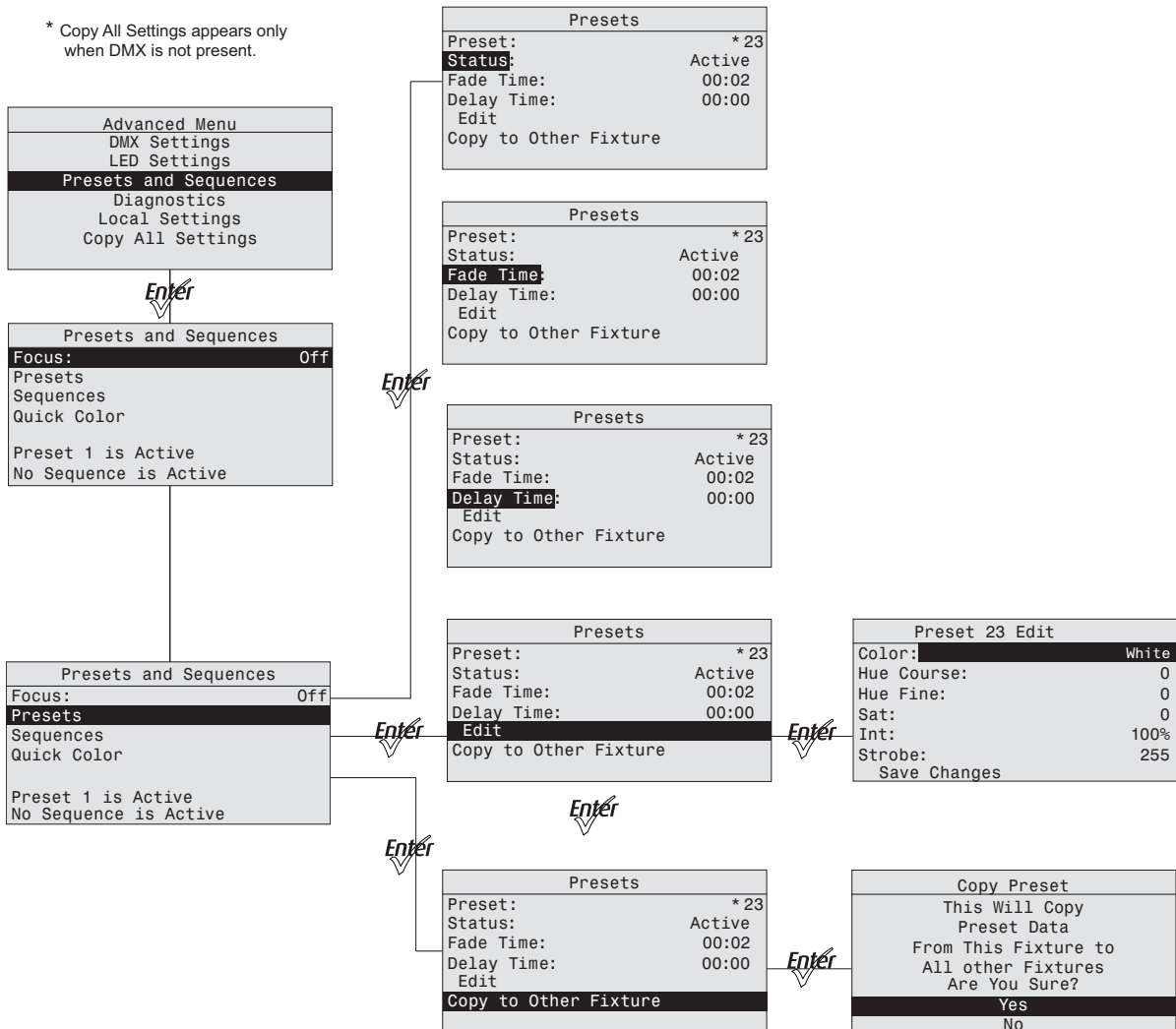

# Presets Menu (Studio Daylight and Studio Tungsten)

```

Advanced Menu
DMX Settings
LED Settings
Presets and Sequences
Diagnostics
Local Settings
Copy All Settings
    
```

*Enter*

```

Presets and Sequences
Focus: Off
Presets
Sequences

Preset 1 is Active
No Sequence is Active
    
```

```

Presets and Sequences
Focus: Off
Presets
Sequences

Preset 1 is Active
No Sequence is Active
    
```

```

Presets
Preset: * 23
Status: Active
Fade Time: 00:02
Delay Time: 00:00
Edit
Copy to Other Fixture
    
```

```

Presets
Preset: * 23
Status: Active
Fade Time: 00:02
Delay Time: 00:00
Edit
Copy to Other Fixture
    
```

```

Presets
Preset: * 23
Status: Active
Fade Time: 00:02
Delay Time: 00:00
Edit
Copy to Other Fixture
    
```

\* Copy All Settings appears only when DMX is not present.

```

Presets
Preset: * 23
Status: Active
Fade Time: 00:02
Delay Time: 00:00
Edit
Copy to Other Fixture
Save DMX as Preset
    
```

*Enter*

```

Preset 23 Edit
Preset: 23
Int: 100%
Strobe: 0
Save Changes
    
```

```

Presets
Preset: * 23
Status: Active
Fade Time: 00:02
Delay Time: 00:00
Edit
Copy to Other Fixture
    
```

*Enter*

```

Copy Preset
This Will Copy
Preset Data
From This Fixture to
All other Fixtures
Are You Sure?
Yes
No
    
```



# Sequences and Quick Color Menus (Vivid, Lustr+, Fire and Ice, Studio HD)

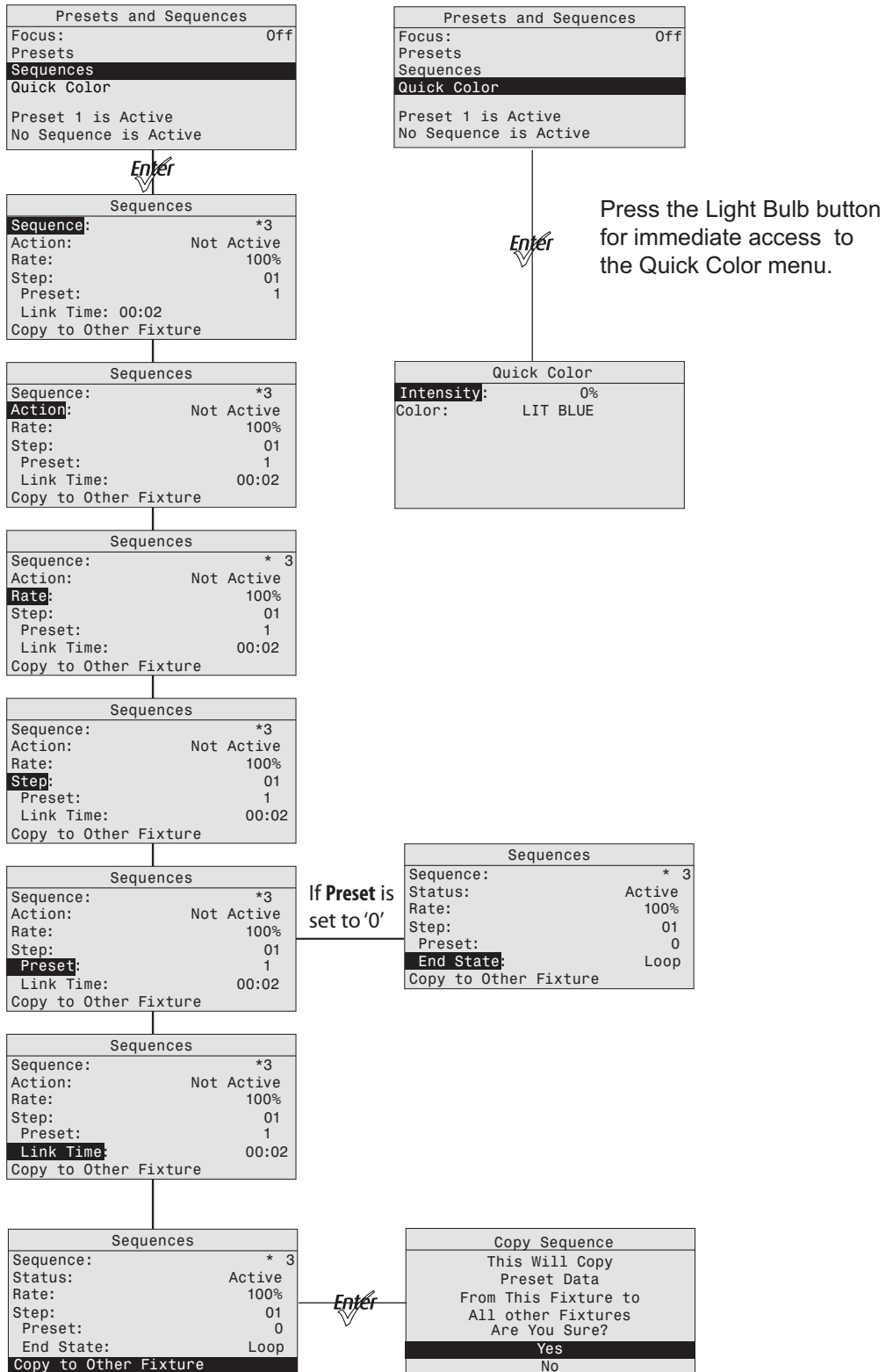

# Diagnostics Menu

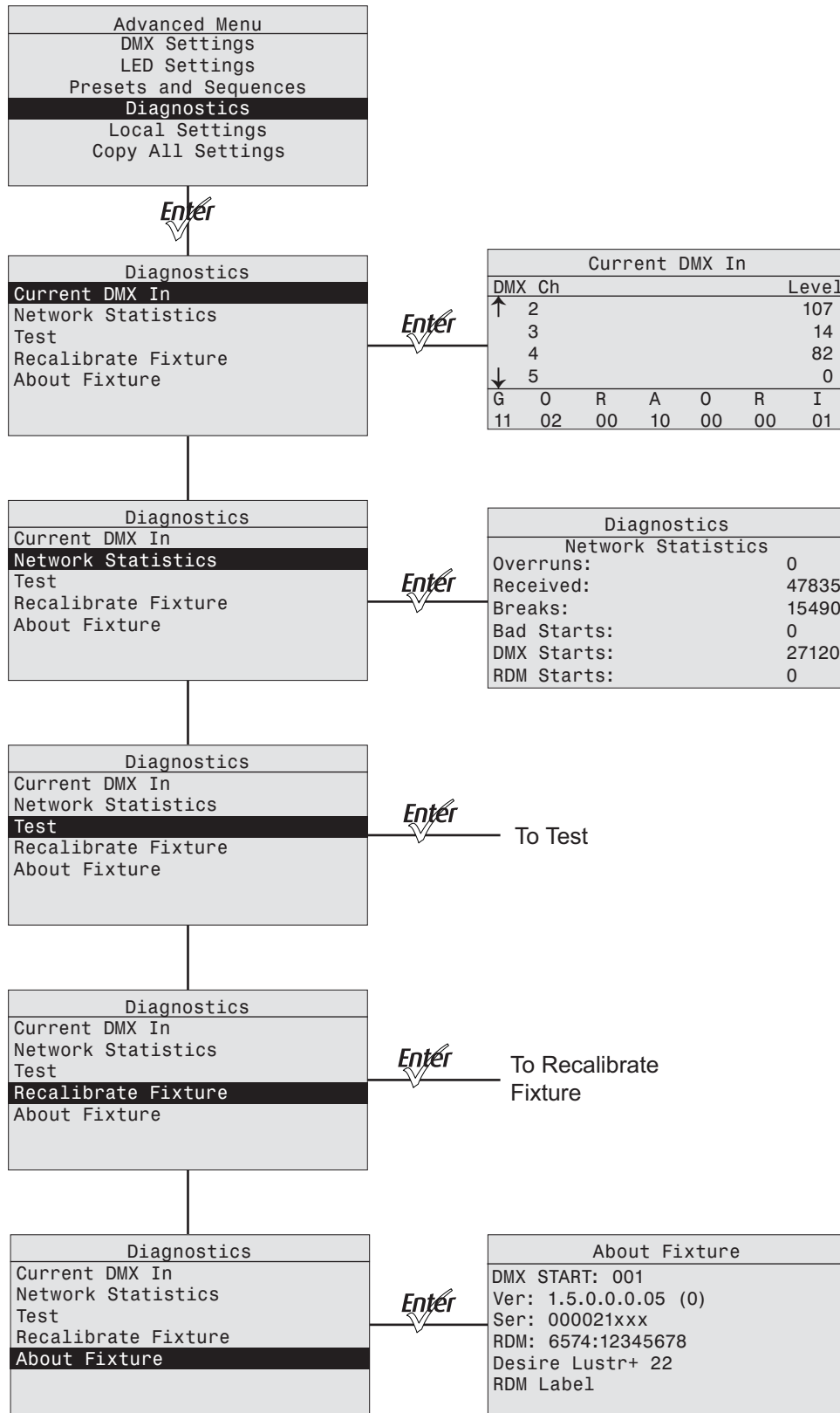

# Diagnostics Test

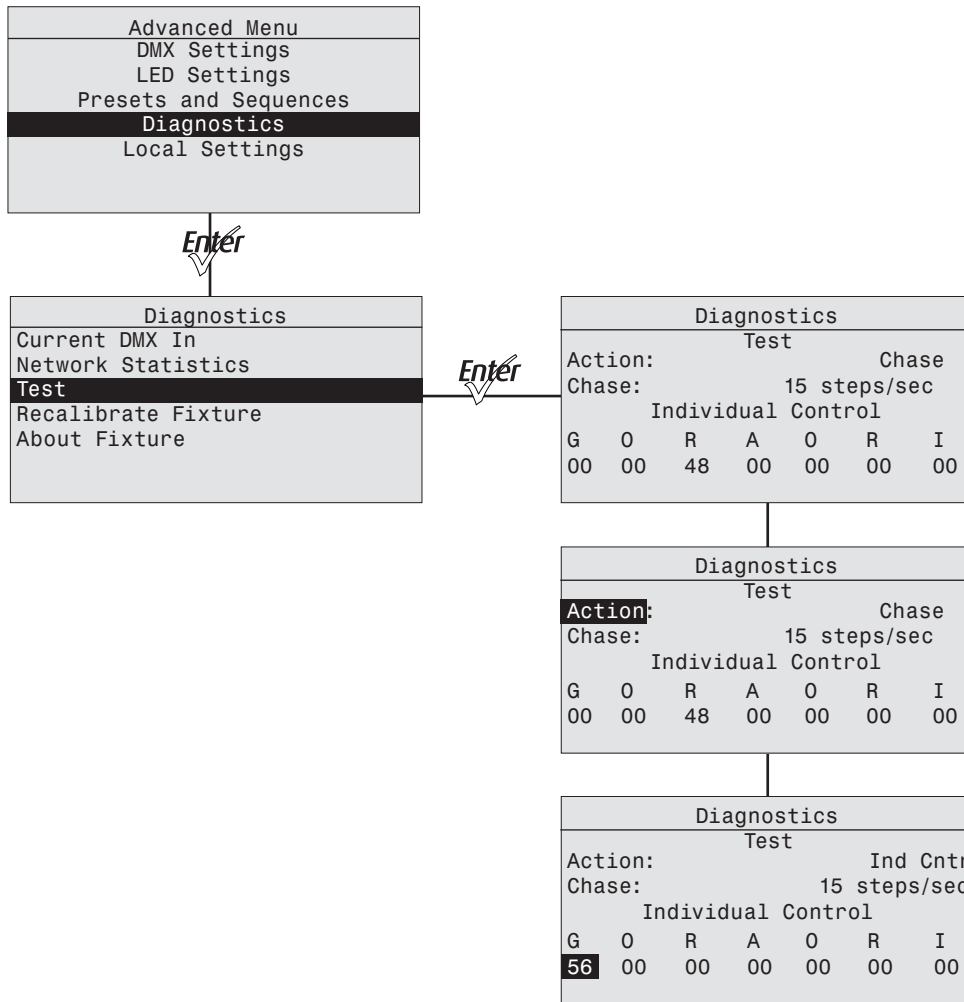

# Diagnostics Recalibrate Fixture

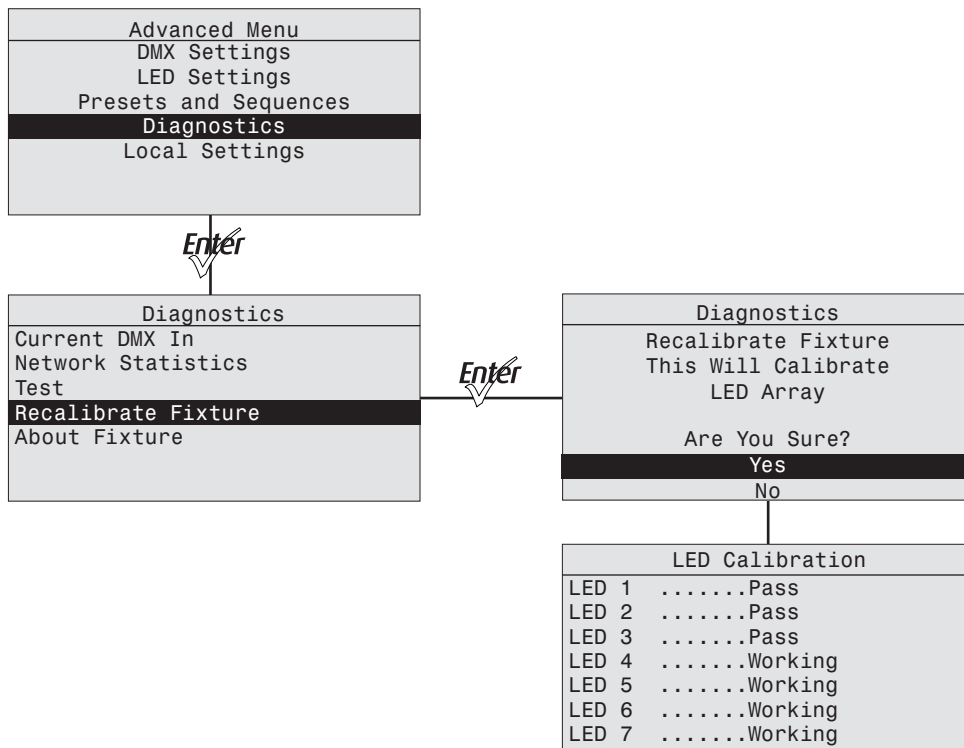

# Appendix B

## RDM Commands

The following table lists the RDM commands applicable to the D60X fixture.

Feature	Get	Set	Queued	RDM Parameter ID	Parameter Values	Enumerations
Status Messages	Yes	No	Yes	E120_STATUS_MESSAGES	—	—
Supported Parameters	Yes	No	Yes	E120_SUPPORTED_PARAMETERS	See RDM E1.20-2006	—
Parameter Description	Yes	No	Yes	E120_PARAMETER_DESCRIPTION	See RDM E1.20-2006	—
Device Info	Yes	No	Yes	E120_DEVICE_INFO	See RDM E1.20-2006	—
Device Model Description	Yes	No	Yes	E120_DEVICE_MODEL_DESCRIPTION	ASCII string for Model Description	—
Manufacturer Label	Yes	No	Yes	E120_MANUFACTURER_LABEL	ASCII string for manufacturer label	—
Device Label	Yes	Yes	Yes	E120_DEVICE_LABEL	ASCII string for device label	—
Factory Defaults	No	Yes	Yes	E120_FACTORY_DEFAULTS	None	—
Software Version Label	Yes	No	Yes	E120_SOFTWARE_VERSION_LABEL	ASCII string for software label	—
DMX Personality	Yes	Yes	Yes	E120_DMX_PERSONALITY	0 thru 7	"7CH, 8CH, HSI, HSIC, RGB, EHSI, EHSIC"
DMX Personality Description	Yes	No	Yes	E120_DMX_PERSONALITY_DESCRIPTION	0 thru 7	"7CH, 8CH, HSI, HSIC, RGB, EHSI, EHSIC"
DMX Start Address	Yes	Yes	Yes	E120_DMX_START_ADDRESS	1 thru 512	DMX Address
Slot Info	Yes	No	No	E120_SLOT_INFO	—	—
Slot Description	Yes	No	No	E120_SLOT_DESCRIPTION	—	—
Default Slot Value	Yes	No	No	E120_DEFAULT_SLOT_VALUE	—	—
Sensor Definition	Yes	No	Yes	E120_SENSOR_DEFINITION	0 thru 8	"LED1, LED2, LED3, LED4, LED5, LED6, LED7, LED Ambient, Control Ambient"
Sensor Value	Yes	No	Yes	E120_SENSOR_VALUE	0 thru 8	"LED1, LED2, LED3, LED4, LED5, LED6, LED7, LED Ambient, Control Ambient"
Identify Device	Yes	Yes	Yes	E120_IDENTIFY_DEVICE	"0, 1"	"Stop Identify, Start Identify"
Reset Device	No	Yes	Yes	E120_RESET_DEVICE	—	—
LED Curve	Yes	Yes	Yes	ETC_LED_CURVE	"0, 1, 2, 3"	"Standard, Incandescent, Linear, Quick"
LED Curve Description	Yes	No	Yes	ETC_LED_CURVE_DESCRIPTION	"0, 1, 2, 3"	"Standard, Incandescent, Linear, Quick"

Feature	Get	Set	Queued	RDM Parameter ID	Parameter Values	Enumerations
Strobe	Yes	Yes	Yes	ETC_LED_STROBE	"0, 1"	"Disabled, Enabled"
Output Mode	Yes	Yes	Yes	ETC_LED_OUTPUT_MODE	"0, 1, 2"	"Regulated, Boost, Protected"
Output Mode Description	Yes	No	Yes	ETC_LED_OUTPUT_MODE_DESCRIPTION	"0, 1, 2"	"Boost, Regulated, Protected"
Red Shift <sup>a</sup>	Yes	Yes	Yes	ETC_LED_RED_SHIFT	"0, 1"	"Disabled, Enabled"
White Point <sup>a</sup>	Yes	Yes	Yes	ETC_LED_WHITE_POINT	"0, 1, 2, 3"	"2950 K, 3200 K, 5600 K, 6500 K"
White Point Description <sup>a</sup>	Yes	No	Yes	ETC_LED_WHITE_POINT_DESCRIPTION	"0, 1, 2, 3"	"2950 K, 3200 K, 5600 K, 6500 K"
Output Frequency	Yes	Yes	Yes	ETC_LED_FREQUENCY	900 thru 1500	Hertz
Data Loss Behavior	Yes	Yes	Yes	ETC_DMUX_LOSS_BEHAVIOR	"0, 1, 2"	"Instant Black, Wait 2 min, HLL"
Data Loss Behavior Description	Yes	No	Yes	ETC_DMUX_LOSS_BEHAVIOR_DESCRIPTION	"0, 1, 2"	"Instant Black, Wait 2 min, HLL"
Plus Seven <sup>a</sup>	Yes	Yes	Yes	ETC_LED_PLUS_SEVEN	"0, 1"	"Disable, Enable"
Backlight Brightness	Yes	Yes	Yes	ETC_BACKLIGHT_BRIGHTNESS	0 thru 255	"0 = off, 255 = max brightness"
Backlight Timeout	Yes	Yes	Yes	ETC_BACKLIGHT_TIMEOUT	"0, 1, 2, 3, 4"	"0 = Never, 1 = 30sec, 2 = 1min, 3 = 5min, 4 = 15min"
Status Indicators	Yes	Yes	Yes	ETC_STATUS_INDICATORS	"0, 1"	"0 = Indicators Off, 1 = On"
Recalibrate Fixture	No	Yes	No	ETC_RECALIBRATE_FIXTURE	—	—
Over Temp Mode	Yes	Yes	Yes	E120_ETC_OVERTEMPMODE	"0, 1"	"0 = Dark, 1 = Visible"
Quick Setup Mode	Yes	Yes	Yes	E120_ETC_SIMPLESETUPMODE	"0, 1, 2, 3, 4, 5"	"0 = General, 1 = Stage, 2 = Arch, 3 = Effects, 4 = Studio, 5 = Advanced"
LED Strobe Description	Yes	No	No	E120_ETC_LED_STROBE_DESCRIPTION	"0, 1"	—
LED Red Shift Description <sup>a</sup>	Yes	No	No	E120_ETC_LED_RED_SHIFT_DESCRIPTION	"0, 1"	—
LED Plus Seven Description <sup>a</sup>	Yes	No	No	E120_ETC_LED_PLUS_SEVEN_DESCRIPTION	"0, 1"	—
Backlight Timeout Description	Yes	No	No	E120_ETC_BACKLIGHT_TIMEOUT_DESCRIPTION	"0, 1, 2, 3, 4"	—
Quick Setup Description	Yes	No	No	E120_ETC_SIMPLESETUPMODE_DESCRIPTION	"0, 1, 2, 3, 4, 5"	—
Over Temp Description	Yes	No	No	E120_ETC_OVERTEMPMODE_DESCRIPTION	"0, 1"	—
Prepare For Software Download	No	Yes	No	E120_ETC_PREPAREFORSOFTWAREDOWNLOA D	—	—
Get requested CIE 1931 (x,y) coordinate	Yes	No	No	E120_ETC_LED_REQUESTED_XY	0 to 32767	0 = 0.0 32767 = 1.0

Feature	Get	Set	Queued	RDM Parameter ID	Parameter Values	Enumerations
Get current CIE 1931 (x,y) coordinate	Yes	No	No	E120_ETC_LED_CURRENT_XY	0 to 32767	0 = 0.0 32767 = 1.0
Get current PWM duty cycle	Yes	No	No	E120_ETC_LED_CURRENT_PWM	0 to 32767	—
Get LED CIE Tristimulus values	Yes	No	No	E120_ETC_LED_TRISTIMULUS	See ETC Manf RDM doc	—
Get LED information	Yes	No	No	E120_ETC_LED_INFORMATION	See ETC Manf RDM doc	—

a) Fire, Ice, Studio, Lustr+ only



Corporate Headquarters Middleton, WI, USA +1 608 831 4116 London, UK +44 (0)20 8896 1000  
Holzkirchen, DE +49 (80 24) 47 00-0 Rome, IT +39 (06) 32 111 683 Hong Kong +852 2799 1220 Paris, FR +33 1 4243 3535  
Web [etccconnect.com](http://etccconnect.com) Support [support.etccconnect.com](http://support.etccconnect.com) Contact [etccconnect.com/contactETC](http://etccconnect.com/contactETC)  
© 2020 Electronic Theatre Controls, Inc. Trademark and patent info: [etccconnect.com/ip](http://etccconnect.com/ip)  
Product information and specifications subject to change. ETC intends this document to be provided in its entirety.  
7410M1200-1.8.1 Rev B Released 2020-10