

NET3™ Four-Port Gateway Setup Guide

Overview

This Setup Guide will guide you through the setup of the Net3 Four-Port DMX/RDM gateway (version 5.x software and later) including hardware, electrical and data connections. Software configuration of your gateway is covered separately and relates specifically to the software versions that may be running in the gateways.

- For **Net3** configuration, please refer to the Gateway Configuration Editor (GCE) Online Help System.

Ethernet Connection

- PoE (IEEE 802.3af)
- 10/100Mbps data speeds
- Auto-sensing
- Auto-negotiation
- RJ45 and etherCON compatible

Menu Button

- Activates the LCD backlight
- Advances display pages

Power Indicator

- Solid blue LED indicates power

Reset Button

- hard reboot

LCD

- Displays gateway status and configuration data

Activity Indicator

- Solid green LED indicates network connection.
- Flashing LED indicates network activity

Four Module Bays

- use any combination of modules including the blank plate, DMX Out (XLR Female), DMX In (XLR Male), RJ45 and terminal strip modules.

Strain Relief

- strain relief clip for dc power cable

DC Power Input

- 8-28Vdc
- Positive tip
- 3.5mm barrel
- 5 Watts usage

Power Indicator

- Solid blue LED indicates power

Grounding Post

Activity Indicator

- Solid green LED indicates network connection.
- Flashing LED indicates network activity

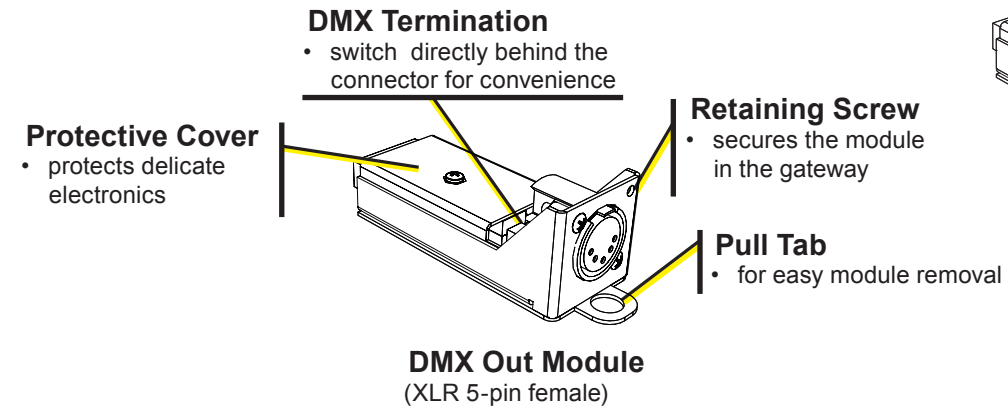

DMX RJ45 Module
(RJ45 8-pin female)

DMX In Module
(XLR 5-pin male)

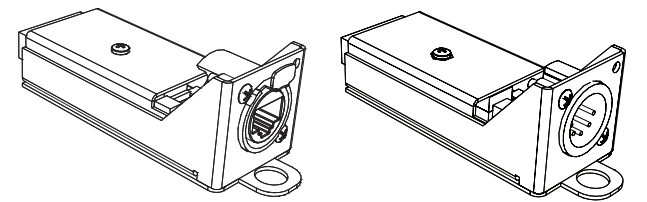

DMX Terminal Strip Module
(8-pin male)

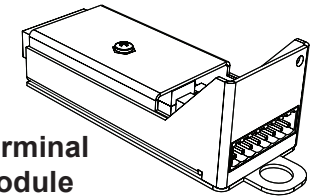

DMX Gateway Modules

There are four different modules available for use in the Four-Port gateway: DMX Out (5-pin female), DMX In (5-pin male), RJ45 (8-pin female for input or output) and DMX Terminal Strip (8-pin Weidmuller for input or output).

- The terminal strip module comes with ETC's standard DMX termination preparation kit (part number 4100A012) which includes instructions and all parts required for installation. If you are connecting to Category 5 wire for DMX, request the DMX termination preparation kit with IDC connectors from ETC (part number 4100A1013).
- The DMX RJ45 module can use a standard Category 5 cable to transmit DMX512 to other devices utilizing the same connector.

NOTE: The DMX RJ45 module will not function as an Ethernet network port.

Any of these modules may be configured as DMX input or DMX output using configuration software. Additionally, there is a blanking plate for any unused module bay.

WARNING: RISK OF ELECTRIC SHOCK! Power must be removed from the gateway before removing any modules or covers to service the unit.

With power removed from the Gateway, you can move and swap DMX modules as needed for required configuration or replacement.

Help from ETC Technical Services

If you experience difficulty during setup or installation of the Net3 gateway, additional information is available from www.etconnect.com, or by contacting ETC Technical Services at your local office listed on the bottom left side of this document.

DMX Basics and Pin-Outs

The Net3 Four-Port gateway sends and receives DMX512 control signals. This unit can contain up to four DMX ports in any combination using 5-pin DMX input connectors, 5-pin DMX output connectors, RJ45 connectors, or terminal strip connectors. DMX cables must be acceptable for DMX data transmission (not microphone cable) and connections should follow the standard pinouts per the charts below. The optional secondary data pair is not used by the Net3 Four-Port gateway.

DMX512 Pinout for 5-pin XLR Connectors			
Female (output)	Pin#	Use	Male (input)
	1	Common (shield)	
	2	Data -	
	3	Data +	
	4	unused	
	5	unused	

DMX512 Pinout for RJ45 Connectors			
Female	Pin#	Use	Wire Color
	1	Data 1 +	White/Orange
	2	Data 1 -	Orange
	3	not used	White/Green
	4	not used	Blue
	5	not used	White/Blue
	6	not used	Green
	7	Signal Common	White/Brown
	8	Signal Common	Brown

DMX512 Pinout for Terminal Strip Connector			
Female	Pin#	Use	Wire Color
	1	Common (shield)	Clear/Shield
	2	Data -	Black
	3	Data +	Red
	4	unused	
	5	unused	
	6	unused	
	7	unused	
	8	unused	



Corporate Headquarters ■ 3031 Pleasant View Road, P.O. Box 620979, Middleton, Wisconsin 53562-0979 USA ■ Tel +608 831 4116 ■ Fax +608 836 1736
 London, UK ■ Unit 26-28, Victoria Industrial Estate, Victoria Road, London W3 6UU, UK ■ Tel +44 (0)20 8896 1000 ■ Fax +44 (0)20 8896 2000
 Rome, IT ■ Via Pieve Torina, 48, 00156 Rome, Italy ■ Tel +39 (06) 32 111 683 ■ Fax +44 (0) 20 8752 8486
 Holzkirchen, DE ■ Ohmstrasse 3, 83607 Holzkirchen, Germany ■ Tel +49 (80 24) 47 00-0 ■ Fax +49 (80 24) 47 00-3 00
 Hong Kong ■ Rm 1801, 18/F, Tower 1 Phase 1, Enterprise Square, 9 Sheung Yuet Road, Kowloon Bay, Kowloon, Hong Kong ■ Tel +852 2799 1220 ■ Fax +852 2799 9325
 Service: (Americas) service@etconnect.com ■ (UK) service@etceurope.com ■ (DE) techserv-hoki@etconnect.com ■ (Asia) service@etcasia.com
 Web: www.etconnect.com ■ Copyright © 2011 ETC. All Rights Reserved. ■ Product information and specifications subject to change.
 4260M2201 ■ Revision A ■ 2011-05

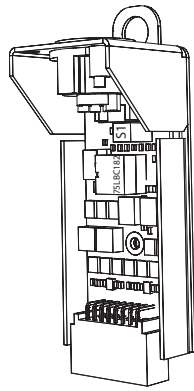

DMX Termination

The DMX network supports up to 32 devices connected to each DMX line. Termination is required for all DMX networks and belongs at the source (beginning) of a DMX network line and at the last device physically connected in the line. A termination switch is located on each DMX module (yellow switch labeled Termination S1) to enable or disable DMX termination. This switch is factory defaulted to "On" for every module. The most common reason to disable termination is to support "touch and go" connections. "Touch and go" implies that you land DMX wiring on the input connector for the gateway and continue to another DMX device (daisy-chain). This practice is uncommon when using DMX gateways.

Replacing the DMX Transceiver Chip

Occasionally a DMX device can encounter an electrical surge that causes the DMX transceiver chip to fail. This DMX chip (mfg# 75LBC182 / ETC# Z1458-F) is located under the cover next to the termination switch. As needed, you can replace this DMX chip with another. It is best to remove this chip with an IC puller, if the tool is available to you.

RDM Basics

Net3 gateway software supports Remote Device Management (RDM) protocol. By default, RDM discovery is not enabled on Net3 gateways. To enable RDM on the Net3 Four-Port gateway, use ETC's Net3 Gateway Configuration Editor (GCE) software. Please see the GCE online help files for more information on activating RDM on your Net3 gateways.

About RDM

Remote Device Management (RDM) is a protocol enhancement to DMX512 that allows bidirectional communication between a lighting system controller and attached RDM-compliant responder devices over a standard DMX line. This protocol allows configuration, status monitoring, and management of these devices.

An RDM Controller is the device that initiates communication with one or more RDM Responder devices. Examples of responders are RDM-enabled edge devices such as color scrollers, dimmers, moving lights, and LED fixtures. RDM supports 32 RDM devices per-port, just like DMX. Compliant DMX512 and DMX512-A devices (non-RDM devices) are fully functional when RDM is present. RDM was developed by ESTA Technical Standards and can also be referenced as ANSI E1.20.

Optional Accessories

Rack Mount Kit (4260K1001)

The Net3 Gateway Rack Mount kit is capable of holding up to two Net3 Gateways for mounting into a standard 19" rack enclosure. If you only need to mount one unit, a blanking plate is provided with the kit. This blanking plate can be installed on either side of the rack mount bracket.

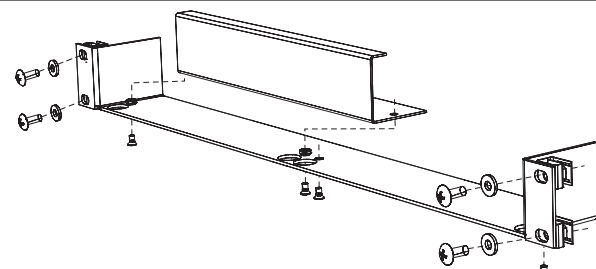

Hanging Hardware Kit (4260K1005)

The Net3 Hanging Hardware kit allows pipe mounting of a Net3 Gateway in a variety of orientations. You can vary the way the U-bolt (or c-clamp) attaches to the bracket and the way the bracket mounts to the gateway. The bracket attaches to any edge on the bottom of your gateway.

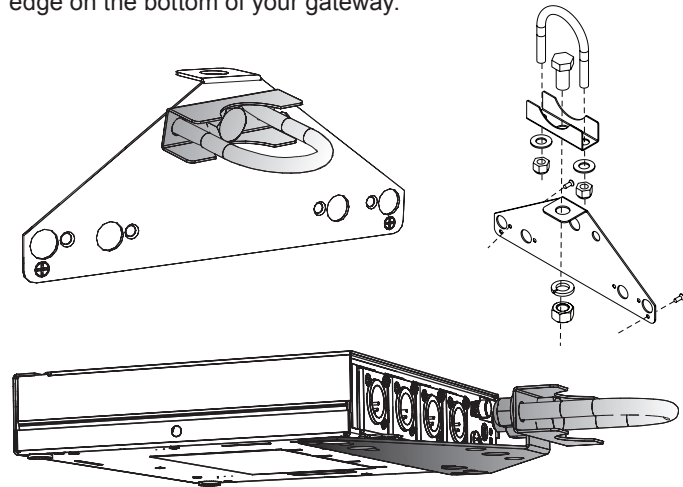

DMX Front Panel Kits

4260K1002 - DMX out / 4260K1003 - 2 DMX in / 2 DMX out

These kits provides front panel access to the DMX connectors on a Net3 Four-Port Gateway when installed in an equipment rack. You must use these kits in combination with one Net3 Four-Port gateway and a Rack Mount Kit (4260K1001), not included.

A connector blanking plate (4260A3013) is required to cover an unused connector opening when fewer than four DMX connectors are required on the front panel.

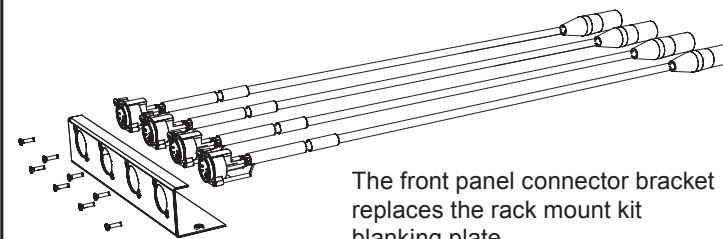

The front panel connector bracket replaces the rack mount kit blanking plate.

Power Up Using DC Power

When using an external power supply, the gateway must be connected to a network before being powered.

Menu Structure

The Net3 Four-Port gateway has only a one button interface. Pressing the **[Menu]** button repeatedly cycles through the menu, displaying mostly informational data. On certain menu items you are prompted to press and hold the **[Menu]** button for a period of 5 seconds to change a state or switch between operating modes. The Net3 menu structure is displayed below for your convenience.

