

COLORADO™ 1-QUAD TOUR

User Manual

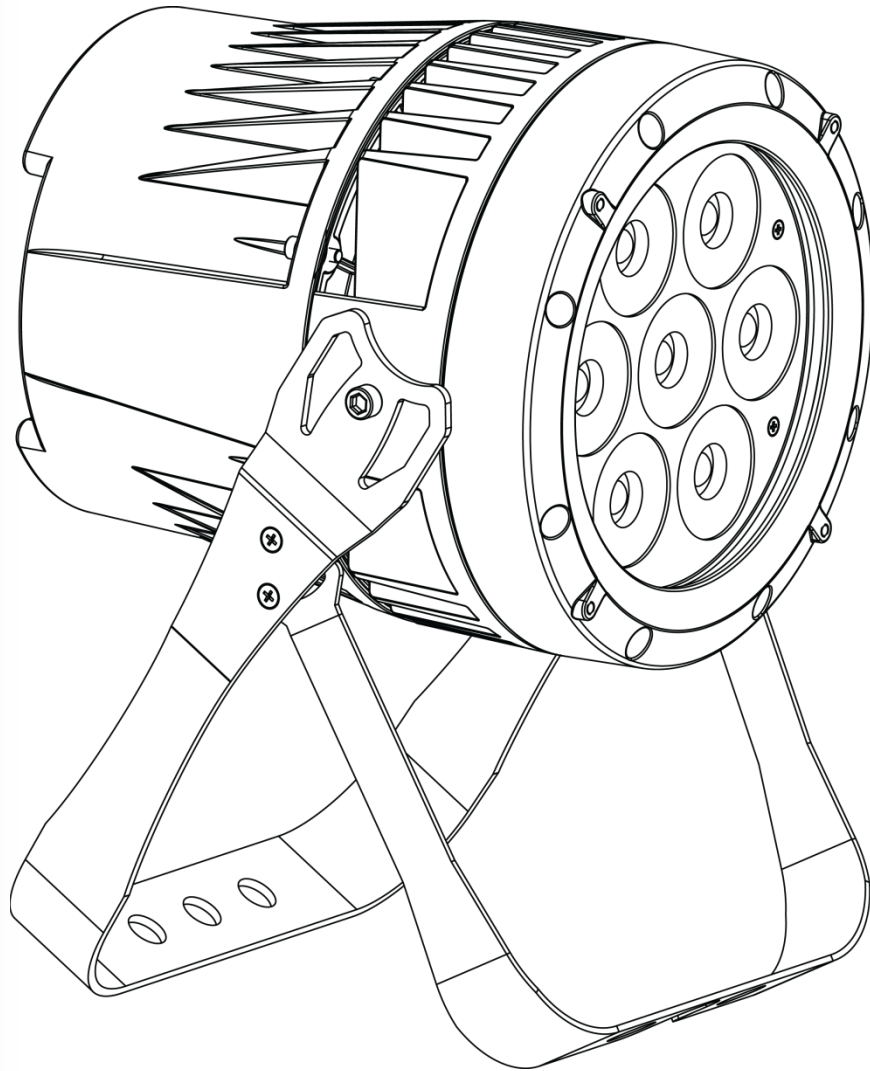

CHAUVET[®]
PROFESSIONAL

Edition Notes

The COLORado™ 1-Quad Tour User Manual Rev. 4 covers the description, safety precautions, installation, programming, operation, and maintenance of the COLORado™ 1-Quad Tour. Chauvet released this edition of the COLORado™ 1-Quad Tour User Manual in April 2015.

Trademarks

CHAUVET® is a registered trademark of CHAUVET & Sons Inc. (d/b/a CHAUVET® or Chauvet). The CHAUVET® logo in its entirety including the CHAUVET® name and the dotted triangle, and all other trademarks in this manual pertaining to services, products, or marketing statements are owned or licensed by Chauvet. Any other product names, logos, brands, company names, and other trademarks featured or referred to within this document are the property of their respective trademark holders.

Copyright Notice

Chauvet owns the content of this User Manual in its entirety, including but not limited to pictures, logos, trademarks, and resources.

© **Copyright 2015 Chauvet. All rights reserved.**

Electronically published by Chauvet in the United States of America.

Manual Use

Chauvet authorizes its customers to download and print this manual for professional information purposes only. Chauvet expressly prohibits the usage, copy, storage, distribution, modification, or printing of this manual or its content for any other purpose without written consent from Chauvet.

Document Printing

For better results, print this document in color, on letter size paper (8.5 x 11 in), double-sided. If using A4 paper (210 x 297 mm), configure your printer to scale the content accordingly.

Intended Audience

Any person in charge of installing, operating, and/or maintaining this product should completely read through the guide that shipped with the product, as well as this manual, before installing, operating, or maintaining this product.

Disclaimer

Chauvet believes that the information contained in this manual is accurate in all respects. However, Chauvet assumes no responsibility for any errors or omissions in this document. Chauvet reserves the right to revise and make changes to the content of this document without obligation that Chauvet notify any person or company of such revision or changes. This does not constitute in any way a commitment by Chauvet to make such changes. Chauvet may issue a revision of this manual or a new edition to incorporate such changes.

Document Revision

The COLORado™ 1-Quad Tour User Manual Rev. 4 supersedes all previous versions of this manual. Discard any older versions of this manual you may have, whether in printed or electronic format, and replace with this version.

Author	Date	Editor	Date
D. Coupepe	3/30/15	M. Trouard	4/9/15

Table of Contents

- 1. Before You Begin 1**
 - What Is Included 1
 - Unpacking Instructions 1
 - Claims 1
 - Typographic Conventions 1
 - Symbols 1
 - Safety Notes 2
 - Personal Safety 2
 - Mounting and Rigging 2
 - Power and Wiring 2
 - Operation 2
 - Expected LED Lifespan 2
- 2. Introduction 3**
 - Description 3
 - Features 3
 - Product Overview 4
 - Product Dimensions 5
- 3. Setup 6**
 - AC Power 6
 - AC Plug 6
 - Power Linking 6
 - DMX Linking 7
 - DMX Personalities 7
 - Master/Slave Connectivity 7
 - Mounting 8
 - Orientation 8
 - Rigging 8
- 4. Operation 9**
 - Control Panel Description 9
 - Control Options 9
 - Programming 9
 - DMX Personality 10
 - DMX Control 10
 - Loss of Signal Setting 10
 - Static Color 10
 - Auto Programs 11
 - Edit Custom Programs 11
 - Master/Slave Mode 11
 - Color Settings 11
 - Dimmer Curves 12
 - Curve Settings 12
 - Control Panel Lock 12
 - Passcode 12
 - Settings Lock 12
 - Program Upload 13
 - Reset 13
 - Resetting Calibration Defaults 13
 - Setting the 13
 - White Color 13
 - Calibrating the 14
 - White Color 14
 - TOUR Notes 14
 - Master Dimmer 14

Red, Green, Blue, and White Color Selection	14
Color Macros	14
Strobe	14
Auto/Custom	14
Dimmer Speed	14
Menu Map	15
Menu Options (cont.)	16
DMX Values	17
TOUR	17
DMX Values (cont.)	18
TOUR (cont.)	18
FULL	18
DMX Values (cont.)	19
FULL (cont.)	19
DMX Values (cont.)	20
TR16	20
DMX Values (cont.)	21
TR16 (cont.)	21
PIX1	21
PIX2	21
ARC.1	21
AR1.D	21
ARC.2	21
DMX Values (cont.)	22
AR2.D	22
AR2.S	22
HSV	22
COLORado™ 1-Quad Tour Zones for DMX Control	22
5. Technical Information	23
Product Maintenance	23
Returns	24
Technical Specifications	25
Contact Us	26

1. Before You Begin

What Is Included

- COLORado™ 1-Quad Tour
- Neutrik® powerCON® power cord
- Gel frame holder (7.5 in/191 mm accessories)
- Gel frame
- Warranty card
- Quick Reference Guide

Unpacking Instructions

Immediately upon receiving this product, carefully unpack the items and inspect the box. Make sure you have received all the parts indicated above and that all the parts are in good condition.

Claims

If the box or contents appear damaged from shipping, or show signs of mishandling, notify the carrier immediately upon receipt, not Chauvet. Failure to notify the carrier in a timely manner may invalidate your claim. In addition, keep the container and all the packing material for inspection.



For other issues such as missing components or parts, damage not related to shipping, or concealed damage, file a claim with Chauvet within seven (7) days of receiving the merchandise.

See [Contact Us](#) for addresses and phone numbers.

Typographic Conventions

Convention	Meaning
1–512	A range of values in the text
50/60	A set of mutually exclusive values in the text
<i>Claims</i>	A new term, another document reference, or section or chapter in this document
<SET>	A button on the product’s control panel
Settings	A product function or a menu option
MENU > Settings	A sequence of menu options
1–10	A range of menu values from which to choose in a menu
Yes/No	A set of two mutually exclusive menu options in a menu
ON	A unique value to be entered or selected in a menu

Symbols

Symbol	Meaning
	Critical installation, configuration, or operation information. Failure to comply with this information may render the product partially or completely inoperative, damage third-party equipment, or cause harm to the user.
	Important installation or configuration information. Failure to comply with this information may prevent the product from functioning correctly.
	Useful information.



The term “DMX” used throughout this manual refers to the USITT DMX512-A digital data transmission protocol.

Safety Notes

Read all the following Safety Notes before working with this product. These notes include important information about the installation, usage, and maintenance of this product.



There are no user-serviceable parts in this product. Any reference to servicing in this User Manual applies only to properly certified Chauvet technicians. Do not open the housing or attempt any repairs unless you are certified by Chauvet.



All applicable local codes and regulations apply to proper installation of this product.

Personal Safety

- Avoid direct eye exposure to the light source while the product is on.
- Always disconnect this product from its power source before servicing.
- Always connect this product to a grounded circuit to avoid the risk of electrocution.
- Do not touch this product's housing during operation because it may be very hot.

Mounting and Rigging

- This product is for indoor use only! To prevent risk of fire or shock, do not expose this product to rain or moisture.
- CAUTION: When transferring product from extreme temperature environments, (e.g. cold truck to warm humid ballroom) condensation may form on the internal electronics of the product. To avoid causing a failure, allow product to fully acclimate to the surrounding environment before connecting it to power.
- Make sure there are no flammable materials close to this product while it is operating.
- When hanging this product, always secure to a fastening device using a safety cable.

Power and Wiring

- Always make sure you are connecting this product to the proper voltage in accordance with the specifications in this manual or on the product's specification label.
- To eliminate unnecessary wear and improve its lifespan, during periods of non-use completely disconnect the product from power via breaker or by unplugging it.
- Never connect this product to a dimmer pack or rheostat.
- Never disconnect this product by pulling or tugging on the power cable.

Operation

- Do not operate this product if you see damage on the housing, lenses, or cables. Have the damaged parts replaced by an authorized technician at once.
- Do not cover the ventilation slots when operating to avoid internal overheating.
- The maximum ambient temperature is 113 °F (45 °C). Do not operate this product at a higher temperature.
- In case of a serious operating problem, stop using this product immediately!



In the unlikely event that your Chauvet product may require service, contact Chauvet Technical Support.

Expected LED Lifespan

LEDs gradually decline in brightness over time, mostly because of heat. Packaged in clusters, LEDs exhibit higher operating temperatures than in ideal, single-LED conditions. For this reason, using clustered LEDs at their fullest intensity significantly reduces the LEDs' lifespan. Under normal conditions, this lifespan can be 40,000 to 50,000 hours. If extending this lifespan is vital, lower the operating temperature by improving the ventilation around the product and reducing the ambient temperature to an optimal operating range. In addition, limiting the overall projection intensity may also help to extend the LEDs' lifespan.

2. Introduction

Description

The COLORado™ 1-Quad Tour is a high-power quad-color RGBW LED wash product. This product consists of a single module that houses the internal power supply, the main control, the control panel, the LED drivers, the LED boards, as well as the power and signal connectors. The COLORado™ 1-Quad Tour includes one double-bracketed yoke that can be both a floor mount and hanging support bracket.

Features

- 3-, 4-, 5-, 6-, 8-, 10-, 15- or 23-channel quad-color LED wash product
- Operating modes:
 - 3-channel (ARC.1): RGB control
 - 3-channel (HSV): HSV control
 - 4-channel (AR1.D): RGB, dimmer
 - 4-channel (ARC.2): RGBW
 - 5-channel (AR2.D): RGBW, dimmer
 - 6-channel (AR2.S): RGBW, dimmer, strobe
 - 6-channel (PIX1): RGB pixel control
 - 8-channel (PIX2): RGBW pixel control
 - 10-channel (TOUR): RGBW, dimmer, strobe, color macro, white balance, auto/custom, dimmer speed, auto speed
 - 15-channel (TR16): 16-bit RGBW and dimmer; strobe, color macro, white balance, ring effect, dimmer speed, auto speed
 - 23-channel (FULL): 16-bit RGBW, ring control and dimmer; strobe, color macro, ring effect, dimmer speed, auto speed
- RGBW color mixing with or without DMX controller
- 11 color temperature presets
- Built-in automated programs via Master/Slave, DMX
- Recall custom programs via Master/Slave or DMX
- Five distinct dimming curves
- RGBW quad-color LEDs
- Electronic dimmer
- Color macros with speed adjustment included
- Electronic power supply
- 3- and 5-pin DMX input and output connectors

Product Overview

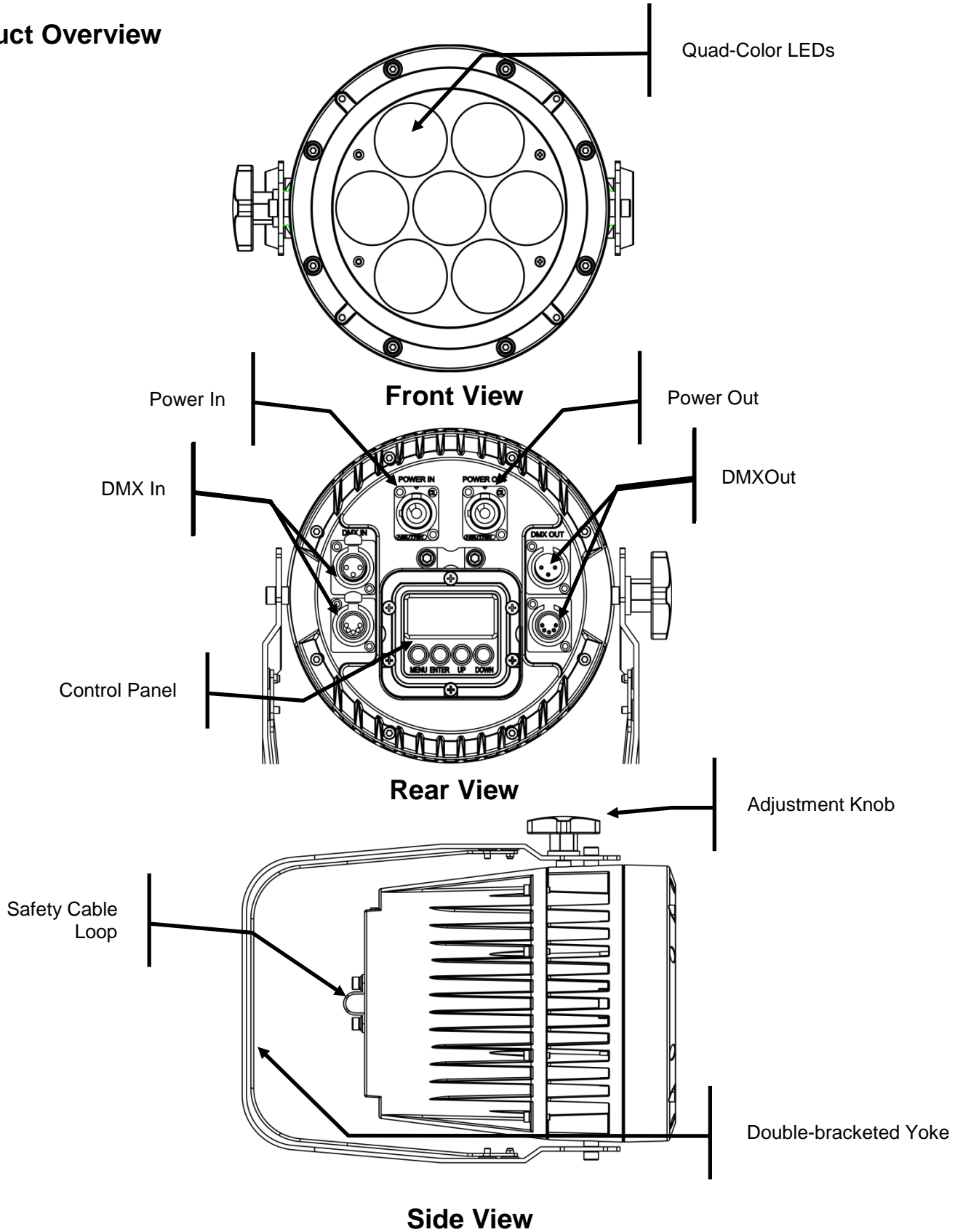

Product Dimensions

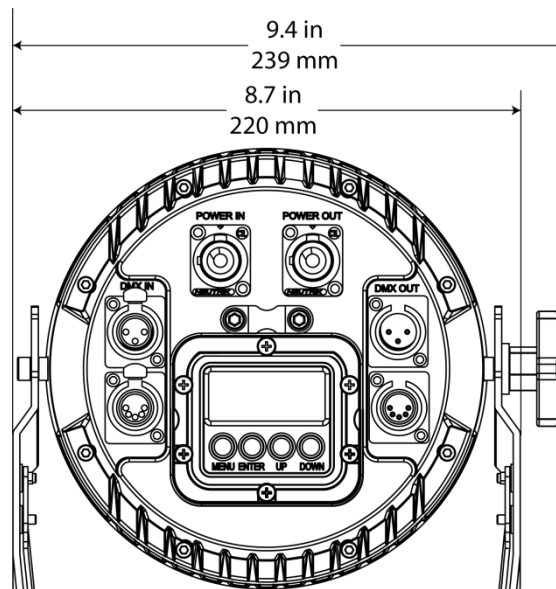
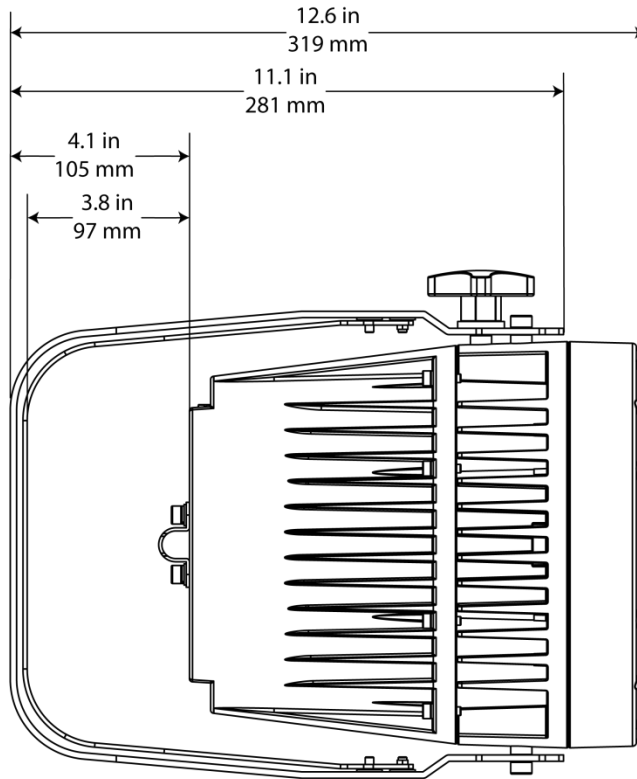

3. Setup

AC Power

The COLORado™ 1-Quad Tour has an auto-ranging power supply that works with an input voltage range of 100 to 240 VAC, 50/60 Hz.

Make sure that you are connecting this product to the proper voltage. To determine the power requirements for the COLORado™ 1-Quad Tour, refer to the specification label affixed to the product or the specifications in this manual.

See the [Technical Specifications](#).



- **Always connect this product to a protected circuit with an appropriate electrical ground to avoid the risk of electrocution or fire.**
- **To eliminate unnecessary wear and improve its lifespan, during periods of non-use completely disconnect the product from power via breaker or by unplugging it.**

The listed current rating indicates the maximum current draw during normal operation. For more information, download *Sizing Circuit Breakers* from the Chauvet website: www.chauvetprofessional.com.



AC Plug

Never connect this product to a rheostat (variable resistor) or dimmer circuit, even if the rheostat or dimmer channel serves only as a 0 to 100% switch.

The COLORado™ 1-Quad Tour comes with a NEUTRIK® powerCON A connector on one end and an Edison plug on the other end (US market). If the power cord adapter that came with your product has no plug or you need to change the Edison plug, use the table below to wire the new plug.

Connection	Wire (U.S.)	Wire (Europe)	Screw Color
AC Live	Black	Brown	Yellow or Brass
AC Neutral	White	Blue	Silver
AC Ground	Green/Yellow	Green/Yellow	Green

Power Linking

The COLORado™ 1-Quad Tour supports power linking. You can power link up to 11 products at 120 V, 19 at 208 V, or 21 at 230 V.

DMX Linking

You can link the COLORado™ 1-Quad Tour to a DMX controller using a standard DMX serial connection. If using other DMX compatible products with the COLORado™ 1-Quad Tour, you can control each individually with a single DMX controller.

DMX Personalities

The COLORado™ 1-Quad Tour uses the standard DMX data connection for the **TOUR**, **TR16**, **FULL**, **ARC.1**, **AR1.D**, **ARC.2**, **AR2.D**, **AR2.S**, **PIX1**, **PIX2**, and **HSV** DMX personalities.

Refer to the [Introduction](#) chapter for a brief description of these personalities.

Refer to the [Operation](#) chapter to learn how to configure the COLORado™ 1-Quad Tour to work in these personalities.

The [DMX Values](#) section provides detailed information regarding the DMX personalities.

Master/Slave Connectivity

The Master/Slave mode allows a COLORado™ 1-Quad Tour (the master) to control one or more COLORado™ 1-Quad Tours (the slaves) without a DMX controller. One COLORado™ 1-Quad Tour becomes the master when running an auto or custom program, or by being in Static (**STAT**) mode.

You must configure each slave's control panel to operate in Slave (**SLAV**) mode. During Master/Slave operation, the slaves will operate in unison with the master.



If you are not familiar with or need more information about DMX standards, Master/Slave connectivity, or the DMX cables needed to link this product to a DMX controller, download the *DMX Primer* from the Chauvet website www.chauvetprofessional.com.



DO NOT connect a DMX controller to products operating in Master/Slave mode. The DMX controller signals may interfere with the signals from the master.



The [Operation](#) chapter of this manual provides detailed instructions on how to configure the master and slaves.

Mounting

Before mounting this product, read and follow the [Safety Notes](#). For our CHAUVET® Professional line of mounting clamps, go to <http://trusst.com/products/>.

Orientation

Always mount this product in a safe position and make sure there is adequate room for ventilation, configuration, and maintenance.

Rigging

The COLORado™ 1-Quad Tour consists of a double-bracketed yoke and the body of the product. Chauvet recommends using the following general guidelines when mounting this product.

- When selecting an installation location, consider easy access to this product for operation, programming adjustments, and routine maintenance.
- Make sure to mount this product away from any flammable material as indicated in the [Safety Notes](#).
- If hanging this product, make sure that the mounting location can support the product's weight. Refer to the [Technical Specifications](#) chart for the weight-bearing requirements of this product.
- When hanging this product, always secure to a fastening device using a safety cable.

Procedure

The COLORado™ 1-Quad Tour comes with a double-bracketed yoke to which you can either attach mounting clamps for hanging or simply use as a floor stand. You must supply your own mounting clamps. Make sure the clamps are capable of supporting the weight of this product. You will have to use at least one mounting point per product.

Product Mounting Diagram

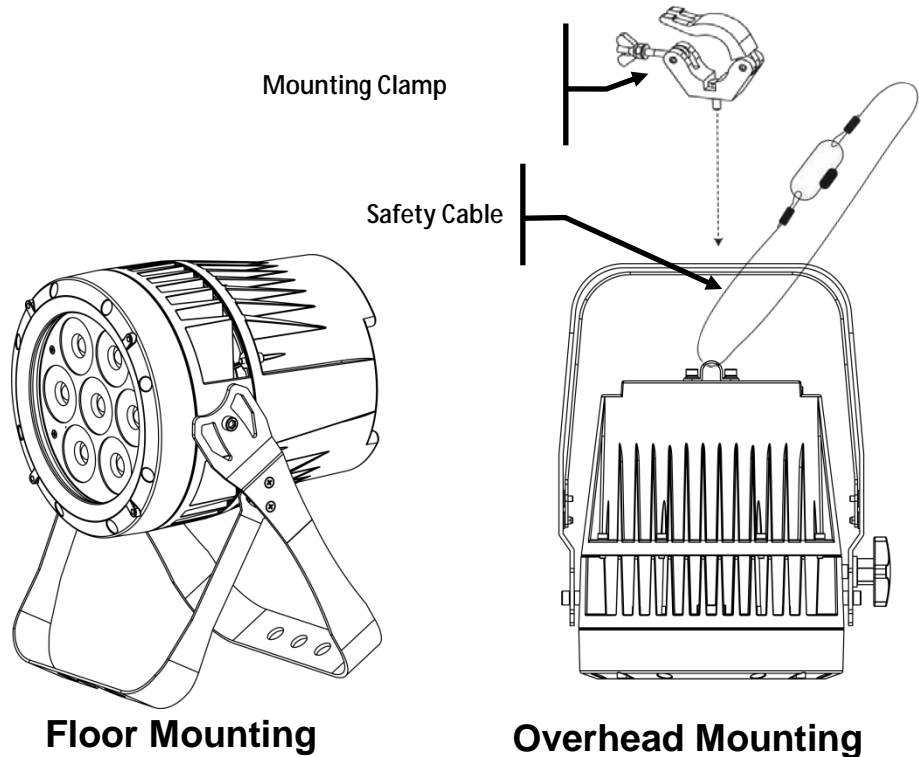

4. Operation

Control Panel Description

Button	Function
<MENU>	Exits from the current menu or function
<ENTER>	Enables the currently displayed menu or sets the currently selected value in to the current function
<UP>	Navigates upward through the menu list and increases the numeric value when in a function
<DOWN>	Navigates downward through the menu list and decreases the numeric value when in a function

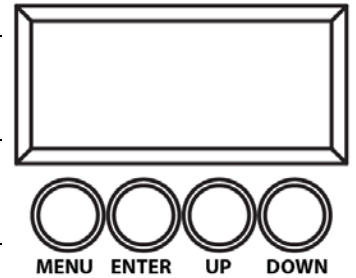

Control Options Programming

You can set the COLORado™ 1-Quad Tour start address in the **001–512** DMX range. This enables control of up to 22 products in the 23-channel **FULL** personality.

Refer to the [Menu Map](#) to understand the menu options. The menu map shows the main level and a variable number of programming levels for each option.

- To go to the desired main level, press **<MENU>** repeatedly until the option shows on the display. Press **<ENTER>** to select. This will take you to the first programming level for that option.
- To select an option or value within the current programming level, press **<UP>** or **<DOWN>** until the option shows on the display. Press **<ENTER>** to select. In this case, if there is another programming level, you will see that first option, or you will see the selected value.
- Press **<MENU>** repeatedly to exit to the previous main level.

DMX Personality

This setting allows you to choose a particular DMX personality.

1. Go to the **PERS** main level.
2. Select the desired personality (**TOUR**, **TR16**, **FULL**, **ARC.1**, **AR1.D**, **ARC.2**, **AR2.D**, **AR2.S**, **PIX1**, **PIX2**, and **HSV**).
 - See the [DMX Values](#) section for the highest starting address you can select for each personality.
 - Make sure that the starting addresses on the various products do not overlap due to the new personality setting.



DMX Control

In this mode, each product will respond to a unique starting address from the DMX controller. All products with the same starting address will respond in unison.

1. Select a DMX personality as shown in [DMX Personality](#).
2. Set the running mode:
 - a. Go to the **RUN** main level.
 - b. Select the **DMX** programming level.
3. Set the starting address:
 - a. Go to **DMX** main level.
 - b. Select the starting address (**001–512**).

The highest recommended starting address for each DMX mode are as follows:

DMX Mode	DMX Address	DMX Mode	DMX Address	DMX Mode	DMX Address
TOUR	503	ARC.2	509	HSV	510
ARC.1	510	AR2.D	508	TR16	498
AR1.D	509	AR2.S	507	FULL	490
PIX1	507	PIX2	505		



Loss of Signal Setting

This setting controls how the product will respond when the DMX signal is lost.

1. Go to the **SET** main level.
2. Select **DERR**.
 - a. Select **SAVE** to make the product use the last command used when the signal is lost.
 - b. Select **BLAK** to turn off the all the LEDs when the signal is lost.

Static Color

The Static Color mode allows for permanent RGBW color mixing without a DMX controller.

1. Go to the **STAT** main level.
2. Select the desired color (**RED**, **GRN**, **BLUE**, or **WHIT**).
3. Select the desired color value (**000–255**).
4. Repeat for the other colors.
5. Select **STRB**.
6. Select the desired frequency (**00–20**).

Auto Programs

Auto programs allow for dynamic RGBW color mixing without a DMX controller.

1. Go to **AUTO**.
2. Select the desired auto (**AT. 01–10**) or custom program (**PR. 01–10**).
 - a. If **AT. 01–10** is selected; choose the speed (**000–255**).



Edit Custom Programs

You cannot edit any of the auto programs (**AUTO 01–10**). However, you can edit the custom programs (**PR.01–10**). See [Edit Custom Programs](#) below for details.

This setting allows the programming of up to 30 scenes for each of the 10 customizable programs, including colors and effects.

1. Go to the **EDIT** main level.
2. Select the desired auto program (**PR. 01–10**).
3. Select the desired scene (**SC. 01–30**).
4. Select the desired color or effect (**RED, GREN, BLUE, WHIT, STRB, TIME, or FADE**).
5. Select the color or effect value (**000–255** for colors and timers, or **00–20** for strobe).
6. Repeat for the other colors or effects.
7. Return to the scene (**SC. 01–30**) level.
8. Repeat the settings of colors and effects for the other scenes.

Master/Slave Mode

The Master/Slave mode allows a group of COLORado™ 1-Quad Tours (the slaves) to simultaneously duplicate the output of another COLORado™ 1-Quad Tour (the master) without a DMX controller.

1. Set each of the slaves:
 - a. Go to **RUN**.
 - b. Select **SLAVE**.
 2. Set the master product:
 - a. Set the running mode to **DMX** as explained in [DMX Control](#).
 - b. Select an auto or custom program as explained in *Auto Programs* above, or a static mix of colors.
- The master is the one that runs a program whether in Auto, Custom or Static Color mode.
 - Do not connect a DMX controller to the products configured for Master/Slave operation. The DMX controller may interfere with signals from the master.
 - The master should be the first product in the daisy chain.



Color Settings

The **COLOR** setting determines how the COLORado™ 1-Quad Tour generates the white color based on various RGB settings.

1. Go to the **SET** main level.
2. Select **COLO**.
3. Select **OFF, RGBW, or UC**.

OFF: When all the RGB faders are set to **255**, the output is maximum, although the resulting white color may not be balanced.



RGBW: When all the RGB faders are set to **255**, the resulting output is defined by the configured white color (see [Calibrating the White Color](#)).

UC: When all the RGB faders are set to **255**, the output matches that of less efficient products (Universal Color).

Dimmer Curves

This setting determines how fast the output of the COLORado™ 1-Quad Tour changes when you modify the values of the red, green, blue, white, and dimmer faders. This setting provides four different options to simulate the dimming curve of an incandescent lighting product.

1. Go to the **SET** main level.
2. Select **DIM**.
3. Select a dimmer curve (**OFF**, **DIM1**, **DIM2**, **DIM3**, or **DIM4**).

OFF: The output is proportional (linear) to the dimmer and RGBW channel values.
DIM1–4: The output follows the dimmer and RGBW channel values based on the corresponding dimmer curve, **DIM1** being the fastest and **DIM4** the slowest.



Curve Settings

This setting allows you to select the dimmer curve shape using the red, green, blue, white, and dimmer faders.

1. Go to the **SET** main level.
2. Select **CURV**.
3. Select a dimmer curve (**OFF**, **CV1**, **CV2**, or **CV3**).

OFF: The output is proportional (linear) to the dimmer and RGBW channel values.
CV1–3: The output follows the dimmer and RGBW channel values based on the corresponding dimmer curve, **CV1** being the fastest and **CV3** the slowest.



For optimum control of the 16-bit dimming channels in the TR16 and FULL personalities, be sure that both dimming curves in SET > DIMX and SET > CURV are set to OFF.

Control Panel Lock

This setting enables you to activate or disable the control panel lock, which keeps non-authorized personnel from changing the product's settings.

1. Go to the **SET** main level.
2. Select **KEY**.
3. Select **ON** or **OFF**.



Passcode

When the control panel lock is active, the product will prompt you to enter the passcode after 30 seconds of control panel inactivity or after turning on the product.

After being prompted to enter the passcode:

- Press **<UP>**, **<DOWN>**, **<UP>**, **<DOWN>**, **<ENTER>**.

This passcode cannot be changed and must be used whenever prompted.

Settings Lock

This setting enables you to activate or disable the settings lock, which keeps non-authorized personnel from making any changes to the programming levels under the **SET** main level.

1. Go to the **SET** main level.
2. Select **SLCK**.
3. Select **ON** or **OFF**.



When the settings lock is activated, in order to access the **SET** programming levels, the product will prompt you to enter the passcode. Enter the passcode as described in [Passcode](#).

Program Upload

This option allows you to copy the custom programs of one COLORado™ 1-Quad Tour onto other COLORado™ 1-Quad Tour's by using the Master/Slave mode.

1. Configure and connect the products in a Master/Slave arrangement, where the master has the custom programs you want to transfer to the slaves.
2. From the master, go to the **SET** main level.
3. Select **UPLD**.
4. When **PASS** shows, press **<ENTER>**.
5. Enter the passcode as shown in [Passcode](#).
6. When **SEND** shows, press **<ENTER>** to start the upload.
7. Wait for the upload process to finish (the display will show **END** before continuing or turning the products off).

The Master/Slave products will provide the status of the process by lighting up as follows:

- Yellow indicates that the upload process is running.
- Green indicates that the upload process completed successfully.
- Red indicates that the upload process failed due to an error. Recheck all cable connections and restart the process. If the issue persists, contact Chauvet Technical Support.



Reset

DO NOT upload the data from a COLORado™ 1-Quad Tour to a different product. The other product may become inoperative.

This setting allows you to reset the COLORado™ 1-Quad Tour to the default values, including the custom programs.

1. Go to the **SET** main level.
2. Select **REST**.
3. When **PASS** shows, press **<ENTER>**.
4. Enter the passcode as described in [Passcode](#).
5. Wait for the reset process to finish.

Resetting Calibration Defaults

This setting allows you to reset the product's default values set in the **CAL1** and **CAL2** programming levels. (See [Setting the White Color](#) for **CAL1** settings and [Calibrating the White Color](#) for **CAL2** settings.)

1. Go to the **CAL** main level.
2. When **PASS** shows, press **<ENTER>**.
3. Enter the passcode as described in [Passcode](#).
4. Select **CALR**.
5. Enter the passcode as described in [Passcode](#).
6. Wait for the reset process to finish.

Setting the White Color

This setting allows you to select and edit the color temperature of the white (macros) when in the **TOUR**, **TR16**, or **FULL** modes.

1. Go to the **CAL** main level.
2. Enter the passcode as described in [Passcode](#).
3. Go to **CAL1**.
4. Select a white color (**WH.01–11**).
5. Select a color (**RED**, **GRN**, **BLUE**, or **WHIT**).
6. Select a color value (**000–255**).
7. Repeat for the other colors.

Calibrating the White Color

This setting allows you to select the white color shown by the COLORado™ 1-Quad Tour when the color setting is **RGBW** and the DMX controller's red, green, and blue faders are set to **255**.

1. Go to the **CAL** main level.
2. Enter the passcode as described in [Control Panel Lock](#)
3. Go to **CAL2**.
4. Select a color (**RED**, **GREN**, or **BLUE**).
5. Select a color value (**000–255**).
6. Repeat for the other colors.



When selecting **CAL > CAL2 > RGB.W**, you will only be able to define the values of **RED**, **GREN** (green), and **BLUE**.



The values of RED, GREN (green), and BLUE configured from CAL > CAL2 > RGBW will define the color temperature shown when the RGB faders are set to "255" if SET > COLO > RGBW is active.

TOUR Notes Master Dimmer

These notes clarify the way the **TOUR** DMX personality works.

Red, Green, Blue, and White Color Selection

- Channel 1 controls the intensity of the currently projected color.
- When the slider is at the highest position (**100%**), the intensity of the output is at maximum.
- Channels 2 through 5 control the intensity ratio of each of the red, green, blue, and white LEDs.
- When these channels are at the highest position (**100%**), the intensity of each color is at maximum if **SET > COLO** is **OFF**.
- You can combine channels 2 through 5 to create over one trillion colors.

Color Macros

- Channel 6 selects the required color macro.
- Channel 6 has priority over channels 2 through 6.
- Channel 1 controls the intensity of the color macro.

Strobe

- Channel 7 controls the strobe frequency (not the intensity) of channels 2 through 6.
- Channel 7 can strobe channels 2 through 5 when not running macros, allowing the individual faders (R, G, B, and W), as well as channel 1 (D), to control the output intensity.
- Channel 7 can strobe channel 6 when running macros, allowing channel 6 to select the macro and channel 1 to control the output intensity.

Auto/Custom

- Channel 8 selects the preset auto programs **AT.01–10** or the custom programs **PR.01–10**.
- Channel 8 has priority over channels 2 through 7.
- Channel 9 controls the speed at which each auto program plays.

Dimmer Speed

- Channel 10 selects the Dimmer mode and speed. Dimmer mode provides four different options to simulate the dimming curve of an incandescent lighting product.
- When dimmer is set to **OFF**, the changes in the RGBW and Master Dimmer faders are linear.
- When dimmer is set to **DIM1–DIM4**, **DIM1** is the fastest dimmer curve and **DIM4** is the slowest.

Menu Map

Main Level	Programming Levels			Description	
STAT	RED	000–255		Combines red, green, blue, and white to make a custom color (0–100%)	
	GREN				
	BLUE				
	WHIT				
	STRB	00–20		Selects the strobe frequency (0–20 Hz)	
AUTO	AT.	01–10	000–255	10 automatic programs	
	PR.	01–10		10 customizable programs	
RUN	DMX			DMX mode	
	SLAV			Master/Slave mode	
DMX	D.	001–512		Selects the DMX starting address	
PERS	TOUR			10-channel: RGBW, dimmer, strobe, color macro, white balance, auto/custom, dimmer speed, auto speed,	
	TR16			15-channel: 16-bit RGBW and dimmer; strobe, color macro, white balance, ring effect, dimmer speed, auto speed	
	FULL			23-channel: 16-bit RGBW ring control and dimmer; strobe, color macro, white balance, ring effect, dimmer speed, auto speed	
	ARC.1			3-channel: RGB control	
	AR1.D			4-channel: RGB, dimmer	
	ARC.2			4-channel: RGBW control	
	AR2.D			5-channel: RGBW, dimmer	
	AR2.S			6-channel: RGBW, dimmer, strobe	
	HSV			3-channel: HSV control	
	PIX1			6-channel: RGB pixel control	
PIX2			8-channel: RGBW pixel control		
EDIT	PR. 01–10	SC. 01–30	RED	000–255	Combines red, green, blue, and white to generate a custom color (0–100%)
			GREN		
			BLUE		
			WHIT		
	STRB		00–20	Selects the strobe frequency (0–20 Hz)	
	TIME		000–255	Defines the step duration (slow to fast)	
	FADE			Defines the fade duration (slow to fast)	

Menu Options (cont.)

Main Level	Programming Levels			Description		
SET	KEY	ON		Turns the passcode on or off		
		OFF				
	UPLD	PASS (Enter Passcode)	SEND/ END	Uploads custom programs to other COLORado™ 1-Quad Tour products		
	REST	PASS (Enter Passcode)		Defaults product to factory settings		
	COLO	OFF		RGB set to 255 = max. output		
		RGBW		RGB set to 255 = balanced white		
		UC.		Universal color balance		
	DIM	OFF		No dimmer		
		DIM	DIM1		Dimmer curves	
			DIM2			
			DIM3			
			DIM4			
	CURV	OFF		No dimmer		
		CV1		Fast (CV1) to slow (CV3) dimmer curves		
		CV2				
CV3						
DERR	SAVE		Continues with last command upon loss of DMX control			
	BLAK		Blacks out fixture upon loss of DMX			
SLCK	OFF		SET main level access lock			
	ON					
CAL	PASS (Enter Passcode)	CAL1	WH. 01–11	RED	000–255	Modifies the color macros used in the TOUR , FULL , and TR16 personalities
			CAL2	RED		
		GREN		BLUE		
		BLUE		WHIT		
	CALR	PASS (Enter Passcode)		Defaults CAL to factory settings		

DMX Values

TOUR	Channel	Function	Value	Percent/Setting
	1	Dimmer	000 ó 255	0–100%
	2	Red	000 ó 255	0–100%
	3	Green	000 ó 255	0–100%
	4	Blue	000 ó 255	0–100%
	5	White	000 ó 255	0–100%
	6	Color Macro + White Balance	000 ó 010	No function
			011 ó 030	R: 100% G: 0–100% B: 0
			031 ó 050	R: 100%–0 G: 100% B: 0
			051 ó 070	R: 0 G: 100% B: 0–100%
			071 ó 090	R: 0 G: 100%–0 B: 100%
			091 ó 110	R: 0–100% G: 0 B: 100%
			111 ó 130	R: 100% G: 0 B: 100%–0
			131 ó 150	R: 100% G: 0–100% B: 0–100%
			151 ó 170	R: 100%–0 G: 100%–0 B: 100%
			171 ó 200	R: 100% G: 100% B: 100% W: 100%
			201 ó 205	White 1
			206 ó 210	White 2
			211 ó 215	White 3
			216 ó 220	White 4
			221 ó 225	White 5
			226 ó 230	White 6
			231 ó 235	White 7
	236 ó 240	White 8		
	241 ó 245	White 9		
	246 ó 250	White 10		
	251 ó 255	White 11:		
	7	Strobe	000 ó 009	No function
			010 ó 255	0–20 Hz
	8	Auto + Custom Programs	000 ó 040	No function
			041 ó 049	Auto 1
			050 ó 059	Auto 2
			060 ó 069	Auto 3
			070 ó 079	Auto 4
			080 ó 089	Auto 5
			090 ó 099	Auto 6
			100 ó 109	Auto 7
			110 ó 119	Auto 8
			120 ó 129	Auto 9
			130 ó 139	Auto 10
			140 ó 149	Custom 1
			150 ó 159	Custom 2
			160 ó 169	Custom 3
			170 ó 179	Custom 4
			180 ó 189	Custom 5
			190 ó 199	Custom 6
	200 ó 209	Custom 7		
	210 ó 219	Custom 8		
	220 ó 229	Custom 9		
	230 ó 255	Custom 10		

DMX Values (cont.)

TOUR (cont.)	Channel	Function	Value	Percent/Setting
		9	Auto Speed	000 ó 255
	10	Dimmer Speed	000 ó 009 010 ó 029 030 ó 069 070 ó 129 130 ó 189 190 ó 255	Preset dimmer speed from display menu Linear dimmer Nonlinear dimming curve 1 (fastest) Nonlinear dimming curve 2 Nonlinear dimming curve 3 Nonlinear dimming curve 4 (slowest)

FULL	Channel	Function	Value	Percent/Setting
		1	Dimmer	000 ó 255
	2	Fine Dimmer	000 ó 255	0–100%
	3	Red	000 ó 255	0–100%
	4	Fine Red	000 ó 255	0–100%
	5	Green	000 ó 255	0–100%
	6	Fine Green	000 ó 255	0–100%
	7	Blue	000 ó 255	0–100%
	8	Fine Blue	000 ó 255	0–100%
	9	White	000 ó 255	0–100%
	10	Fine White	000 ó 255	0–100%
	11	Red	000 ó 255	0–100%
	12	Fine Red	000 ó 255	0–100%
	13	Green	000 ó 255	0–100%
	14	Fine Green	000 ó 255	0–100%
	15	Blue	000 ó 255	0–100%
	16	Fine Blue	000 ó 255	0–100%
	17	White	000 ó 255	0–100%
	18	Fine White	000 ó 255	0–100%
	19	Color Macro + White Balance	000 ó 010 011 ó 030 031 ó 050 051 ó 070 071 ó 090 091 ó 110 111 ó 130 131 ó 150 151 ó 170 171 ó 200 201 ó 205 206 ó 210 211 ó 215 216 ó 220 221 ó 225 226 ó 230 231 ó 235 236 ó 240 241 ó 245 246 ó 250 251 ó 255	No function R: 100% G: 0–100% B: 0 R: 100%–0 G: 100% B: 0 R: 0 G: 100% B: 0–100% R: 0 G: 100%–0 B: 100% R: 0–100% G: 0 B: 100% R: 100% G: 0 B: 100%–0 R: 100% G: 0–100% B: 0–100% R: 100%–0 G: 100%–0 B: 100% R: 100% G: 100% B: 100% W: 100% White 1 White 2 White 3 White 4 White 5 White 6 White 7 White 8 White 9 White 10 White 11
	20	Strobe	000 ó 010 011 ó 255	No function 0–20 Hz

DMX Values (cont.)

FULL (cont.)	Channel	Function	Value	Percent/Setting
	21	Ring Effect	000 ó 009	All rings
			010 ó 054	Static ring 1
			055 ó 099	Static ring 2
			100 ó 119	Effect ring 1
			120 ó 139	Effect ring 2
			140 ó 159	Effect ring 3
			160 ó 179	Effect ring 4
			180 ó 184	Static ring color 1
			185 ó 189	Static ring color 2
			190 ó 194	Static ring color 3
			195 ó 199	Static ring color 4
			200 ó 204	Static ring color 5
			205 ó 209	Static ring color 6
			210 ó 214	Static ring color 7
			215 ó 219	Static ring color 8
			220 ó 224	Static ring color 9
	225 ó 229	Static ring color 10		
	230 ó 234	Static ring color 11		
	235 ó 239	Static ring color 12		
	240 ó 244	Static ring color 13		
	245 ó 249	Static ring color 14		
	250 ó 255	Static ring color 15		
	22	Auto Speed	000 ó 255	0–100% (Only when using values 100 to 179 in Ch. 21)
	23	Dimmer Speed	000 ó 009	Preset dimmer speed from display menu
			010 ó 029	Linear dimmer
			030 ó 069	Nonlinear dimming curve 1 (fastest)
			070 ó 129	Nonlinear dimming curve 2
			130 ó 189	Nonlinear dimming curve 3
			190 ó 255	Nonlinear dimming curve 4 (slowest)

DMX Values (cont.)

TR16	Channel	Function	Value	Percent/Setting
	1	Dimmer	000 ó 255	0–100%
	2	Fine Dimmer	000 ó 255	0–100%
	3	Red	000 ó 255	0–100%
	4	Fine Red	000 ó 255	0–100%
	5	Green	000 ó 255	0–100%
	6	Fine Green	000 ó 255	0–100%
	7	Blue	000 ó 255	0–100%
	8	Fine Blue	000 ó 255	0–100%
	9	White	000 ó 255	0–100%
	10	Fine White	000 ó 255	0–100%
	11	Color Macro + White Balance	000 ó 010 No function 011 ó 030 R: 100% G: 0–100% B: 0 031 ó 050 R: 100%–0 G: 100% B: 0 051 ó 070 R: 0 G: 100% B: 0–100% 071 ó 090 R: 0 G: 100%–0 B: 100% 091 ó 110 R: 0–100% G: 0 B: 100% 111 ó 130 R: 100% G: 0 B: 100%–0 131 ó 150 R: 100% G: 0–100% B: 0–100% 151 ó 170 R: 100%–0 G: 100%–0 B: 100% 171 ó 200 R: 100% G: 100% B: 100% W: 100% 201 ó 205 White 1 206 ó 210 White 2 211 ó 215 White 3 216 ó 220 White 4 221 ó 225 White 5 226 ó 230 White 6 231 ó 235 White 7 236 ó 240 White 8 241 ó 245 White 9 246 ó 250 White 10 251 ó 255 White 11	
	12	Strobe	000 ó 010 No function 011 ó 255 0–20 Hz	
	13	Ring Effect	000 ó 009 All rings 010 ó 054 Static ring 1 055 ó 099 Static ring 2 100 ó 119 Effect ring 1 120 ó 139 Effect ring 2 140 ó 159 Effect ring 3 160 ó 179 Effect ring 4 180 ó 184 Static ring color 1 185 ó 189 Static ring color 2 190 ó 194 Static ring color 3 195 ó 199 Static ring color 4 200 ó 204 Static ring color 5 205 ó 209 Static ring color 6 210 ó 214 Static ring color 7 215 ó 219 Static ring color 8 220 ó 224 Static ring color 9 225 ó 229 Static ring color 10 230 ó 234 Static ring color 11 235 ó 239 Static ring color 12 240 ó 244 Static ring color 13 245 ó 249 Static ring color 14 250 ó 255 Static ring color 15	

DMX Values (cont.)

TR16 (cont.)	Channel	Function	Value	Percent/Setting
	14	Auto Speed	000 ó 255	0–100% (Only when using values 100 to 179 in Ch. 13)
	15	Dimmer Speed	000 ó 009 010 ó 029 030 ó 069 070 ó 129 130 ó 189 190 ó 255	Preset dimmer speed from display menu Linear dimmer Nonlinear dimming curve 1 (fastest) Nonlinear dimming curve 2 Nonlinear dimming curve 3 Nonlinear dimming curve 4 (slowest)

PIX1	Channel	Function	Value	Percent/Setting
	1	Pixel 1 Red	000 ó 255	0–100%
	2	Pixel 1 Green	000 ó 255	0–100%
	3	Pixel 1 Blue	000 ó 255	0–100%
	4	Pixel 2 Red	000 ó 255	0–100%
	5	Pixel 2 Green	000 ó 255	0–100%
	6	Pixel 2 Blue	000 ó 255	0–100%

PIX2	Channel	Function	Value	Percent/Setting
	1	Pixel 1 Red	000 ó 255	0–100%
	2	Pixel 1 Green	000 ó 255	0–100%
	3	Pixel 1 Blue	000 ó 255	0–100%
	4	Pixel 1 White	000 ó 255	0–100%
	5	Pixel 2 Red	000 ó 255	0–100%
	6	Pixel 2 Green	000 ó 255	0–100%
	7	Pixel 2 Blue	000 ó 255	0–100%
	8	Pixel 2 White	000 ó 255	0–100%

ARC.1	Channel	Function	Value	Percent/Setting
	1	Red	000 ó 255	0–100%
	2	Green	000 ó 255	0–100%
	3	Blue	000 ó 255	0–100%

AR1.D	Channel	Function	Value	Percent/Setting
	1	Dimmer	000 ó 255	0–100%
	2	Red	000 ó 255	0–100%
	3	Green	000 ó 255	0–100%
	4	Blue	000 ó 255	0–100%

ARC.2	Channel	Function	Value	Percent/Setting
	1	Red	000 ó 255	0–100%
	2	Green	000 ó 255	0–100%
	3	Blue	000 ó 255	0–100%
	4	White	000 ó 255	0–100%

DMX Values (cont.)

AR2.D	Channel	Function	Value	Percent/Setting
	1	Dimmer	000 ó 255	0–100%
	2	Red	000 ó 255	0–100%
	3	Green	000 ó 255	0–100%
	4	Blue	000 ó 255	0–100%
	5	White	000 ó 255	0–100%

AR2.S	Channel	Function	Value	Percent/Setting
	1	Dimmer	000 ó 255	0–100%
	2	Red	000 ó 255	0–100%
	3	Green	000 ó 255	0–100%
	4	Blue	000 ó 255	0–100%
	5	White	000 ó 255	0–100%
	6	Strobe	000 ó 009 010 ó 255	No function 0–20 Hz

HSV	Channel	Function	Value	Percent/Setting
	1	Hue	000 ó 255	0–100%
	2	Saturation	000 ó 255	0–100%
	3	Value	000 ó 255	0–100%

COLORado™ 1-Quad Tour Zones for DMX Control

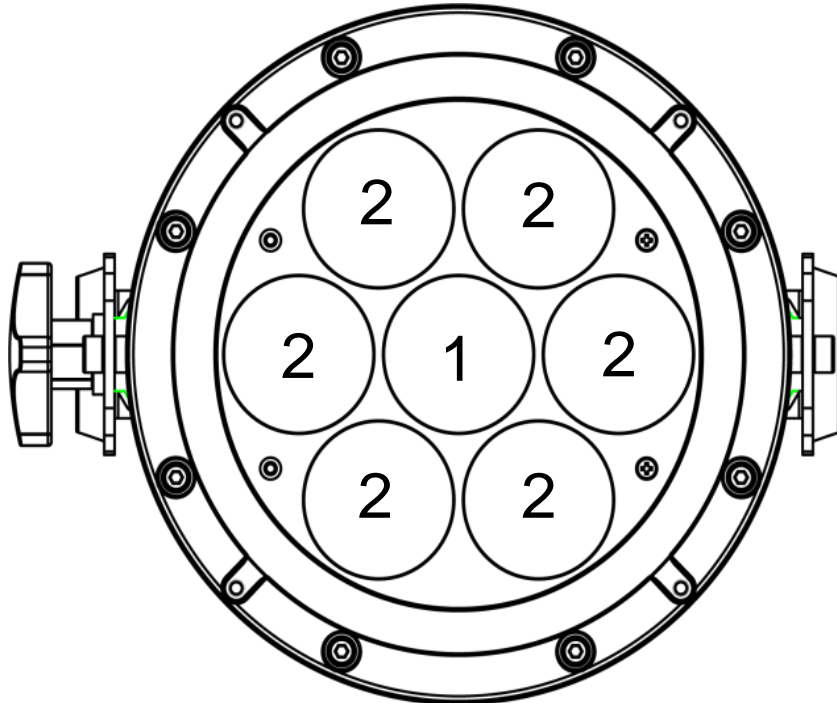

5. Technical Information

Product Maintenance

To maintain optimum performance and minimize wear, you should clean this product frequently. Usage and environment are contributing factors in determining the cleaning frequency.

As a rule, clean this product at least twice a month. Dust build-up reduces light output performance and can cause overheating. This can lead to reduced light source life and increased mechanical wear.

To clean your product:

1. Unplug the product from power.
2. Wait until the product is at room temperature.
3. Use a vacuum (or dry compressed air) and a soft brush to remove dust collected on the external vents.
4. Clean all external surfaces with a mild solution of non-ammonia glass cleaner or isopropyl alcohol.
5. Apply the solution directly to a soft, lint-free cotton cloth or a lens cleaning tissue.
6. Wipe any dirt or grime to the outside edges of the lens surface.
7. Gently polish the lens surfaces until they are free of haze and lint.



Always dry the external surfaces thoroughly and carefully after cleaning them.

Returns

You must send the product prepaid, in the original box, and with the original packing and accessories. Chauvet will not issue call tags.

Call Chauvet and request a Return Merchandise Authorization (RMA) number before shipping the product. Be prepared to provide the model number, serial number, and a brief description of the cause(s) for the return.

Clearly label the package with an RMA number. Chauvet will refuse any product returned without an RMA number.



DO NOT write the RMA number directly on the box. Instead, write it on a properly affixed label.

Once you have received the RMA number, include the following information on a piece of paper inside the box:

- Your name
- Your address
- Your phone number
- The RMA number
- A brief description of the problem(s)

Be sure to pack the product properly. Any shipping damage resulting from inadequate packaging will be the customer's responsibility. FedEx packing or double-boxing are recommended.



Chauvet reserves the right to use its own discretion to repair or replace returned product(s).

Technical Specifications

Dimensions and Weight	Length	Width	Height	Weight
	7.5 in (191 mm)	9.4 in (239 mm)	12.6 in (319 mm)	11.5 lb (5.22 kg)

Note: Dimensions in inches rounded to the nearest decimal digit.

Electrical	Power Supply Type	Range	Voltage Selection
	Switching (internal)	100 to 240 V, 50/60 Hz	Auto-ranging

Parameter	120 V, 60 Hz	230 V, 50 Hz
Consumption	81 W	79 W
Operating	1.15 A	0.63 A
Power linking current (products)	13.6 A (11 products)	13.6 A (21 products)

Power I/O	U.S./Worldwide	Europe
Power input connector	Neutrik® powerCON® A	Neutrik® powerCON® A
Power output connector	Neutrik® powerCON® B	Neutrik® powerCON® B
Power cord plug	Edison (U.S.)	Local plug

Light Source	Type	Power	Lifespan
	LED	10 W	50,000 hours

Color	Quantity	Current
Quad-color (RGBW)	7	2.8 A

Photometrics	Parameter	Standard Optics
	Illuminance @ 5 m	1,520 lx
	Beam angle	11.5°
	Field angle	25°

Thermal	Max. External Temperature	Cooling System
	113 °F (45 °C)	Convection

DMX	I/O Connectors	Connector Type	Channel Range
	3- and 5-pin XLR	Sockets	3, 4, 5, 6, 8, 10, 15 or 23

Ordering	Product Name	Item Code	UPC Number
	COLORado™ 1-Quad Tour	01030096	781462204211



UL 1573
CSA C22.2 No. 166
E113093



Contact Us

WORLD HEADQUARTERS - Chauvet

General Information

Address: 5200 NW 108th Avenue
Sunrise, FL 33351
Voice: (954) 577-4455
Fax: (954) 929-5560
Toll free: (800) 762-1084

Technical Support

Voice: (954) 577-4455 (Press 4)
Fax: (954) 756-8015
Email: tech@chauvetlighting.com

World Wide Web www.chauvetlighting.com

UNITED KINGDOM AND IRELAND - Chauvet Europe Ltd.

General Information

Address: Unit 1C
Brookhill Road Industrial Estate
Pinxton, Nottingham, UK
NG16 6NT
Voice: +44 (0)1773 511115
Fax: +44 (0)1773 511110

Technical Support

Email: uktech@chauvetlighting.com

World Wide Web www.chauvetlighting.co.uk

MEXICO - Chauvet Mexico

General Information

Address: Av. Santa Ana 30
Parque Industrial Lerma
Lerma, Mexico C.P. 52000
Voice: +52 (728) 285-5000

Technical Support

Email: servicio@chauvet.com.mx

World Wide Web www.chauvet.com.mx

CHAUVET EUROPE - Chauvet Europe BVBA

General Information

Address: Stokstraat 18
9770 Kruishoutem
Belgium
Voice: +32 9 388 93 97

Technical Support

Email: Eutech@chauvetlighting.eu

World Wide Web www.chauvetlighting.eu

Outside the U.S., United Kingdom, Ireland, Mexico, or Benelux contact the dealer of record. Follow their instructions to request support or to return a product. Visit our website for contact details.